

TOOLNEWS

FOR PROFESSIONALS

TIMING TOOLS



12 V-RIBBED
BELT TOOL

42 ENGINE
ADJUSTMENT TOOL,
CITROËN/OPEL/
PEUGEOT/TOYOTA

50 TORQUE
MULTIPLIER,
FORD

**BECAUSE ENGINE TECHNOLOGY
DEMANDS PRECISION**

SW STAHL
PROFESSIONAL TOOLS

FOR THOSE WHO LIVE AND BREATHE CARS.

► **SPECIAL TOOLS FOR PROFESSIONALS**

Precise synchronization tools for engine repairs

► **EFFECTIVE SOLUTIONS**

for complex and specific work on vehicles

► **QUALITY AND INNOVATION**

Tools you can rely on

SW STAHL – YOUR PARTNER FOR ENGINE TECHNOLOGY!

tool-is

OUR TOOL DATABASE

QUICK SEARCH FOR YOUR NEW TIMING TOOL.



REGISTER NOW AND VIEW
ADDITIONAL CONTENT!

- ⊗ Fast and flexible online tool search
- ⊗ Display of availability, promotional periods, and prices in real time, among other things
- ⊗ Can also be used on smartphones and tablets
- ⊗ Quick search with automatic search suggestions
- ⊗ Keyword and full-text search
- ⊗ Search by OE numbers, engine codes, item numbers, or vehicle types
- ⊗ German, English, and French
- ⊗ Create watch lists



www.tool-is.com

The „OE numbers“ are only used to compare and identify articles. They must not be stated on invoices to end consumers and are not designations of origin.

COUNTERHOLDER BELT PULLEY, UNIVERSAL

for fixing all belt pulleys, extra long lever and stable design to prevent damage to the components.

- ▶ Diameter approx. 170 mm
- ▶ For V-rib belts and flat belts



Description	Article	Price EUR*
Counterholder belt pulley, universal	10573L	48.50

TURNING SPANNER FOR PULLEYS, UNIVERSAL

for turning over the engine

- ▶ the adjustable roller can be set to each pulley size
- ▶ e.g. for Audi, BMW, Ford, Mercedes, Opel, Peugeot, Renault, Rover, Volvo, VW and various Japanese manufacturers



Description	Article	Price EUR*
Turning spanner for pulleys, universal	10574L	16.90

V-RIBBED BELT TOOL 2-PIECE

This universal V-ribbed belt removal/installation kit is suitable for a wide range of vehicles with elastic stretch belts. The tool is indispensable, as the vehicles do not have a tensioning device and the V-ribbed belt must be pulled on.

Scope of delivery

- ▶ Tool for removal
- ▶ Tool for installation



Description	Article	Price EUR*
V-ribbed belt tool 2-piece	10596L	15.40

V-RIBBED BELT SPANNER TOOL, DOUBLE HEXAGONAL, 5-PIECE

for pre-tensioning the tensioning device for auxiliary belts e.g. for Audi, VW, Ford, Seat, Skoda etc.

- ▶ With angled tips (ca. 45°), ideal where space is tight in the engine compartment
- ▶ Due to the angled shape, no additional removal of components are necessary
- ▶ 19 mm wrench size especially needed for Audi A4, VW Passat from ,97 TDI (pump injector)
- ▶ Non-slip handle for safe work
- ▶ In a practical case
- ▶ Length 460 mm each



Description	Article	Price EUR*
V-ribbed belt spanner tool, double hexagonal, 5-piece	10557L	96.50

PIN-TYPE FACE WRENCH, ADJUSTABLE

for all double-hole nuts from 11 mm gap, with riveted pins, pin diameter 4,1 mm, e.g.

- ▶ For fixing the lock-nut of the angle grinder
- ▶ Also applicable for fitting and removing the visco fan clutch Audi, VW



Description	Article	Price EUR*
Pin-type face wrench, adjustable	S1463	10.10

PIN-TYPE FACE WRENCH WITH INTERCHANGEABLE PINS, 16-PIECE

With replaceable pins and locking by knurled nut:

- ▶ Pin diameter 2.5 - 3 - 4 - 5 - 6 - 7 - 8 - 9 mm
- ▶ Span 102 mm

Ideal as a counter-holder for the following applications:

- ▶ For repairs to transmissions and differentials, e.g. Daimler, Ford, Volvo etc.
- ▶ For viscous fan installation and removal in Audi A4, A6, A8, VW Passat
- ▶ Together with counter-holder 00120L also suitable for Ford, Opel, Vauxhall and GM
- ▶ For removing and mounting vibration dampers in pulley repairs



Description	Article	Price EUR*
Pin-type face wrench with interchangeable pins, 16-piece	S1464	47.00

COUNTERHOLDER, VAG

for VW 1.4 - 1.6 and 2.0 l engines.

- ▶ For counterholding the crankshaft pulley on 4-valve engines with pin diameter 11.5 mm
- ▶ For counterholding the crankshaft timing belt sprocket on 2-valve engines
- ▶ M8 bolt

Suitable for:

- ▶ Audi A2, A3, A4, A5, TT
- ▶ Skoda Fabia, Octavia, Superb
- ▶ VW Bora, Caddy, Golf, Lupo, New Beetle, Polo, Sharan, Touran, Transporter

Engine codes: ADX, AEA, AEE, AEH, AEX, AFH, AFK, AGP, AGR, AHW, AJM, AKL, ALN, AMF, ANA, ANY, APE, APE, APF, ARM, ATJ, AUA, AWH, CGGA, CGPB

Used equivalent to the following OE numbers:

- ▶ T30004
- ▶ 3415



Description	Article	Price EUR*
Counterholder, VAG	10586L	35.50

COUNTERHOLDER CRANKSHAFT, VAG

For crankshaft pulley when loosening and tightening the central bolt on VW 1.6l engines

- ▶ VW Bora, Golf, Lupo, New Beetle, Polo, Caddy
- ▶ Seat Ibiza, Cordoba
- ▶ For engine codes: ARC, ATN, AUS, AVY, AZD, BCB



Seat
VW

Description	Article	Price EUR*
Counterholder crankshaft, VAG	10584L	32.50

V-RIBBED BELT SPANNER TOOL, VAG

for VAG vehicles WITHOUT tensioning roller.

Here, the belt is tensioned via the spring-loaded generator. With the aid of this key, the generator can be turned accordingly to slacken the belt, e.g. during replacement work.

The 12,5 mm (1/2") drive is attached in a star shape and thus allows the tool to be inserted in different ways depending on the space available.

The pins are knurled, reducing the risk of the key slipping out of the generator.

Suitable for the following vehicles:

- ▶ Audi 80 (1991-1995), A2 (2000-2005), A4 (1994-2001), A6 (1994-1997), A6 (1997-2005), Cabriolet (1991-2000)
- ▶ Seat Alhambra (1996-2010), Arosa (1997-2004), Cordoba (1993-2002), Cordoba (2002-2009), Ibiza (1993-2002), Ibiza (2002-2009), Ibiza (2008-2017), Inca (1995-2003), Toledo (1991-1999)
- ▶ Skoda Fabia (1999-2008), Fabia (2006-2014), Felicia (1994-1998), Felicia (1998-2001), Octavia (1996-2010), Roomster (2006-2015)
- ▶ VW Caddy (1995-2004), Caddy (2004-2015), Corrado (1987-1995), Fox (2003-2014), Golf (1991-1999), Golf (1997-2007), Lupo (1998-2005), Passat (1988-1997), Passat (1996-2005), Polo (1994-2001), Polo (2001-2012), Sharan (1995-2010), Vento (1991-1998), Transporter T4 (1990-2004)

Motorcodes:

1F, 1X, 1Y, 1Z, 2E, AAM, AAZ, ABD, ABL, ABS, ABU, ADX, ADY, ADZ, AEA, AEE, AEK, AER, AEX, AEY, AFN, AFT, AGG, AHB, AHH, AHU, AKK, AKP, AKR, AKS, AKV, AKW, ALD, ALE, ALL, ALM, AMF, ANN, ANP, ANV, ANW, ANX, APQ, ATU, AUC, AUD, AVG, AWF, AWG, BAH, BAY, BKR, BMS, BNM, BNV, BWB

Used equivalent to OE number VAG 3297 and Seat U-40050.



Audi
Seat
Škoda
VW

Description	Article	Price EUR*
V-ribbed belt spanner tool, VAG	10582L	23.50

LOCKING TOOL FLYWHEEL, BMW / MINI

For locking the flywheel when loosening and tightening the central screw on the vibration damper on diesel and petrol engines with engine codes:

- ▶ M47T2 / M47TU / M57T2 / M57TU / M67 / N43 / N45 / N45T / N46 / N46T / N47 / N47S / N51 / N52 / N53 / N54 / W17

For the following work, e.g.

- ▶ Exchanging the vibration damper
- ▶ Replacing the crank shaft radial seal ring (on the front)

Suitable for:

- ▶ 116i, 118i, 120i, 128i, 130i, 135i, 135is, 118d, 120d, 123d (E81, E82, E87, E88) / 316i, 318i, 318ti, 320i, 320Si, 323i, 325i, 325xi, 328i, 328xi, 330i, 330xi, 335i, 335xi, 318d, 320d, 320td, 325d, 330d, 330xd, 335d (E46, E90, E91, E92, E93) / 520i, 523i, 525i, 525xi, 530i, 530xi, 535i, 535xi, 520d, 525d, 525xd, 530d, 530xd, 535d, (E60, E61) / 630i, 635d (E63, E64) / 730i, 730d, 740d, (E38, E65, E66) / X3-2.0i, X3-2.0d, X3-3.0d, X5-3.0D, X6-3.5D, X6-3.0d, X6-3.5d (E53, E70, E83) / Z4-2.0i, Z4-2.5i, Z4-3.0i (E85, E86) / Mini One, (R50)

Used equivalent to the following OE numbers:

- ▶ Counter support (complete) 11 8 180
- ▶ Connecting holder 11 8 182
- ▶ Base plate 11 8 183
- ▶ Adaptor (for E65/M67) 11 8 184
- ▶ Adaptor with an adjusting sleeve (for E46/M47TU) 11 8 185



BMW
Mini

Description	Article	Price EUR*
Locking tool flywheel, BMW / Mini	10588L	84.90

COUNTERHOLDER CRANKSHAFT, BMW / MINI / PEUGEOT

for loosening and tightening the crankshaft central screw.

Suitable for:

- ▶ BMW / Mini: N12, N14, N18, N40, N42, N43, N45, N46, N51, N52, N53, N63
- ▶ Peugeot: EP3, EP6, EP6DT, EP6DTS

Used equivalent to the following OE-number:

- ▶ BMW OE-No. T1 9 280



BMW
Mini
Peugeot

Description	Article	Price EUR*
Counterholder crankshaft, BMW / Mini / Peugeot	10589L	33.90

COUNTERHOLDER CRANKSHAFT, OPEL

suitable for Opel Adam, Astra J, Cascada, Corsa D, Insignia, Meriva B, Mokka, Zafira C with 1.0 / 1.2 / 1.4 l ecoFlex engines.

For holding the crankshaft pulley and for releasing the central fixing screw. With the handle included, the counterholder can be extended by 65 cm, thus offering the possibility of releasing fixed screwed connections. An additional 1/2" drive on the anvil alternatively allows use with a sliding handle.

Engine codes: A10XEP, A12XEL (LWD), A12XER (LDC), A14NEL (LUH), A14NET (LUJ), A14XEL (LDD), A14XER (LDD)

Used equivalent to OE numbers:

- ▶ Counterholder basic tool (equivalent to OE EN-49979)
- ▶ Extension for counterholder (equivalent to OE EN-956-1)
- ▶ Adapter, 2-piece (equivalent to OE EN49979-100)



Opel
Vauxhall

Description	Article	Price EUR*
Counterholder crankshaft, Opel	10566L	118.50

GUIDE BOLT LOCK CARRIER, AUDI / VW

for moving the lock carrier to bring the front end into the service position. There is no need to adjust the bonnet lock and the gap dimensions.

Installed in the following vehicles:

- ▶ Audi A4 ,94-'01, A4 ,00-'08, A6 ,97-'05, A6 ,04-'11, A8 ,94-'02, A8 ,02-'09
- ▶ VW Passat ,97-'00

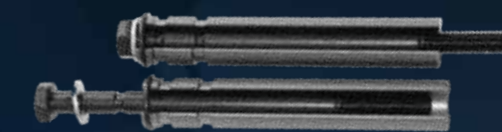

Used equivalent to the following OE numbers:

- ▶ VAG 3369

Description	Article	Price EUR*
Guide bolt lock carrier, Audi / VW	26384L	15.80

GUIDE BOLT LOCK CARRIER, AUDI / VW

The guide bolts allow the front mask (lock carrier) to be pushed away from the engine without dismantling the radiator hoses. They are used instead of the front mask screws.

- ▶ Setting the service position is made possible
- ▶ Helpful e.g. when working on camshafts or changing timing belts
- ▶ Adjusting the hood lock and the gap dimensions is not necessary

Content:

- ▶ 4 guide bolts:
- ▶ 2 x M8
- ▶ 2 x M10

Used equivalent to OE numbers VAG3411 and T10093.



Audi
Seat
Škoda
VW

Description	Article	Price EUR*
Guide bolt lock carrier, Audi / VW	26314L	22.50

ENGINE TIMING TOOL SET, VAG

Very comprehensive universal set for vehicles with VAG petrol and diesel engines. Includes tools for locking the flywheel, crankshaft and camshaft and for adjusting the timing belt tension.

Installed in the following vehicles:

- ▶ Audi A1, A2, A3, A4, A5, A6, A8, Q3, Q5, TT, Coupe, Cabriolet, 80, 100
- ▶ Ford Galaxy
- ▶ Mitsubishi Lancer
- ▶ Seat Alhambra, Altea, Arosa, Cordoba, Exeo, Ibiza, Inca, Leon, Toledo
- ▶ Škoda Fabia, Felicia, Octavia, Rapid, Roomster, Superb, Yeti
- ▶ VW Amarok, Beetle, Bora, Caddy, Eos, Fox, Golf, Jetta, Lupo, Passat, Polo, Scirocco, Sharan, Tiguan, Touran, Vento, LT, Transporter

Engine codes: 1G, 1S, 1T, 1V, 1W, 1X, 1Y, 1Z, 3D, AAB, AAH, AAS, AAT, AAZ, ABC, ABL, ABP, ACK, ACL, ACT, ACV, ADR, AEB, AEF, AEJ, AEL, AEY, AFB, AFF, AFK, AFN, AFY, AGA, AGD, AGE, AGN, AGP, AGR, AGU, AGX, AHA, AHB, AHD, AHF, AHG, AHH, AHU, AHW, AHY, AJA, AJG, AJH, AJK, AJL, AJM, AJP, AJQ, AJT, AJV, AKC, AKE, AKF, AKN, AKQ, AKU, AKW, ALE, ALF, ALG, ALH, ALT, ALW, ALZ, AMB, AMF, AMK, AML, AMM, AMX, ANB, ANJ, ANK, ANM, ANU, ANY, APA, APC, APE, APG, APH, APP, APR, APS, APT, APU, APX, APY, APZ, AQA, AQD, AQE, AQF, AQG, AQH, AQJ, AQQ, AOQ, ARC, ARE, ARG, ARH, ARJ, ARK, ARL, ARN, ARR, ARS, ART, ARU, ARX, ARY, ARZ, ASG, ASJ, ASM, ASV, ASX, ASY, ASZ, ATC, ATD, ATJ, ATL, ATN, ATQ, ATW, ATX, AUA, AUB, AUF, AUG, AUL, AUM, AUQ, AUS, AUW, AUX, AUY, AVB, AVC, AVF, AVG, AVJ, AVP, AVQ, AVR, AVV, AVY, AWC, AWD, AWM, AWN, AWP, AWT, AWU, AWV, AWW, AWX, AWY, AXB, AXC, AXG, AXL, AXP, AXR, AYC, AYM, AYP, AYQ, AYS, AYY, AYZ, AZA, AZD, AZQ, AZR, AZV, BAD, BAM, BAU, BAY, BBD, BBE, BBF, BBG, BBM, BBU, BBY, BBZ, BCA, BCB, BCS, BCY, BCZ, BDG, BDH, BDJ, BDK, BDV, BEA, BEE, BES, BEW, BEX, BFB, BFC, BFL, BFM, BFV, BGK, BGW, BHC, BHW, BJB, BJX, BKC, BKD, BKE, BKF, BKP, BKV, BKY, BLB, BLS, BLT, BLZ, BMA, BMD, BME, BMM, BMN, BMP, BMR, BMS, BMT, BNA, BNM, BNU, BNV, BPW, BPX, BPZ, BRB, BRC, BRD, BRE, BRF, BRR, BRS, BRT, BRU, BRV, BSS, BST, BSU, BSV, BSW, BTB, BUD, BUK, BUZ, BVA, BVE, BVF, BVG, BVH, BVK, BVP, BVR, BWB, BWV, BXE, BXF, BXJ, BXV, BXW, BZG, CAAA, CAAB, CAAC, CAAD, CAEE, CAGA, CAGB, CAGC, CAHA, CAHB, CAYA, CAYB, CAYC, CAYD, CAYE, CBAA, CBAB, CBAC, CBBA, CBBB, CBDA, CBDB, CBDC, CBEA, CCHA, CCHB, CDBA, CDCA, CDDA, CEGA, CEVA, CFCA, CFFA, CFFB, CFFD, CFFE, CFGC, CFGD, CFHA, CFHB, CFHC, CFHD, CFHE, CFHF, CFJA, CFJB, CFMA, CFWA, CGGA, CGGB, CGLA, CGLB, CGLC, CGLD, CGLE, CGPA, CGPB, CGPC, CHFA, CHFB, CHTA, CJAA, CJCA, CJCB, CJCC, CJCD, CJLB, CLCA, CLCB, CLJA, CLLA, CLLB, CLNA, CLPA, CMEA, CMFA, CMFB, CMGA, CMGB, CNEA, CNFA, CNFB, CSHA



Audi
Ford
Mitsubishi
Seat
Škoda
VW

Description	Article	Price EUR*
Engine timing tool set, VAG	26383L	135.90

ENGINE TIMING TOOL SET, SEAT/ŠKODA/VW

contains the most important tools for repair work on 1.2 l. VAG engines with 2- and 4-valve technology..

Suitable for the following vehicles:

- ▶ Seat Cordoba ,02-'08, Ibiza III ,02-'08, Ibiza IV ,08-'17, Toledo IV ,12-'19
- ▶ Škoda Fabia I ,99-'07, Fabia II ,07-'14, Rapid NH, Roomster ,06-'10
- ▶ VW Fox ,05-'11, Polo IV ,01-'09, Polo V ,09-'17

Engine codes: AWY, AZQ, BBM, BMD, BME, BXV, BZG, CEVA, CGPA, CGPB, CGPC, CHFA, CHFB, CHTA, CJLA, CJLB

Used equivalent to the following OE numbers:

- ▶ Locking tool camshafts, VAG T10123
- ▶ Locking tool camshaft, VAG T10120
- ▶ Locking pin crankshaft, VAG T10121



Seat
Škoda
VW

Description	Article	Price EUR*
Engine timing tool set, Seat/Škoda/VW	26354L	28.50

ENGINE TIMING TOOL SET, AUDI / SEAT / ŠKODA / VW

contains the most important tools for repair work on 1.2 TSI and TFSI VAG engines with timing chain.

Suitable for the following vehicles:

- ▶ Audi A1 ,10-'15, A3 ,10-'13
- ▶ Seat Altea/XL ,10-', Ibiza IV ,10-'15, Leon ,12-'15, Toledo IV ,12-'15
- ▶ Škoda Fabia II ,10-'14, Octavia II ,10-'13, Rapid ,12-'15, Roomster ,10-'15, Yeti ,09-'15
- ▶ VW Beetle ,11-'19, Caddy III ,10-'15, Golf VI ,09-'16, Golf Plus ,09-'14, Jetta IV ,10-'17, Polo V ,09-'14, Touran ,10-'15

Engine codes: CBZA, CBZB, CBZC

Used equivalent to the following OE numbers:

- ▶ Locking tool camshaft, VAG T10414
- ▶ Guide pin (2 pieces), VAG T10341
- ▶ Locking pin crankshaft, VAG T10340



Audi
Seat
Škoda
VW

Description	Article	Price EUR*
Engine timing tool set, Audi / Seat / Škoda / VW	26360L	22.50

V-RIBBED BELT SPANNER TOOL SET, 11-PIECE

Universal product for easy removal and installation of elastic V-ribbed belts (e.g. air-conditioning compressor). Also suitable for use with double-belt pulleys. Suitable for the following models:

- ▶ Audi A3
- ▶ BMW T18, T20, T25, T28, T30, T32, T35, T38, T40, T42, T45, T48, T50, T52, T55, T58, T60, T62, T65, T68, T70, X3, X5
- ▶ Chrysler Grand Voyager, Voyager
- ▶ Citroën C2, C3, C4, Jumper, Relay
- ▶ Fiat Albea, Doblo, Ducato, Fiorino, Fiorino Qubo, Linea, Marea, Multipla, Palio, Siena, Stilo, Strada Pick Up
- ▶ Ford C-Max, Focus, Focus C-Max, Fusion, Mondeo, Tourneo, Transit
- ▶ Iveco Daily
- ▶ Lancia Lybra
- ▶ Mazda 2, 3, 5, Axela
- ▶ Mercedes-Benz Sprinter, Viano, Vito
- ▶ Peugeot 206, 207, 307, Boxer
- ▶ Seat Altea, Ibiza
- ▶ Skoda Octavia, Yeti
- ▶ Volvo C30, S40, V50
- ▶ VW EOS, Golf, Passat, Polo, Scirocco



Description	Article	Price EUR*
V-ribbed belt spanner tool set, 11-piece	26341L	130.00

COUNTERHOLDER CAMSHAFT, UNIVERSAL

Adjustable from 40 - 220 mm. Due to the overall length of approx. 500 mm and the associated application of force, ideal e.g. for loosening the fastening screw on injection pumps and for holding the timing belt pulley of the camshaft, etc.

With 4 pairs of retaining pins

- ▶ ø 6 - 10 mm
- ▶ ø 8 - 11 mm
- ▶ ø 10 - 12 mm
- ▶ ø 11 - 16 mm



Description	Article	Price EUR*
Counterholder camshaft, universal	10577L	39.50

ENGINE TIMING TOOL SET, AUDI / SEAT / ŠKODA / VW

for professional engine repair with 1.0 / 1.2 / 1.4 / 1.5 TSI and TFSI as well as 1.6 MPI engines.

Suitable for the following vehicles:

- ▶ Audi A1 (2010-2018), A3 (2012-), A4 (2015-), A5 (2016-), Q2 (2016-), Q3 (2011-)
- ▶ Seat Alhambra (2010-), Ateca (2016-), Ibiza (2008-2017), Ibiza (2016-), Leon (2012-), Mii (2011-), Toledo (2012-)
- ▶ Skoda Citigo (2011-), Fabia (2014-), Kodiaq (2016-), Octavia (2012-), Rapid (2012-), Superb (2015-), Yeti (2009-2017)
- ▶ VW Beetle (2011-), Caddy (2015-), CC (2011-2016), Golf VII (2012-), Jetta (2009-), Passat (2014-), Polo (2009-), Scirocco (2008-2017), Sharan (2010-), Tiguan (2007-2016), Tiguan (2016-), Touran (2015-), up! (2011-)

Engine Codes:

CHPA, CHPB, CHYA, CHYB, CHYC, CHZA, CHZB, CHZC, CHZD, CHZE, CHZF, CHZG, CHZJ, CHZK, CHZL, CJZA, CJZB, CJZC, CJZD, CMBA, CNLA, CPGA, CPTA, CPVA, CPVB, CPWA, CRJA, CSSA, CUKB, CUKC, CVNA, CWLA, CWVA, CWVB, CXSA, CXSB, CXUA, CYVA, CYVB, CYVC, CYVD, CZCA, CZCB, CZCC, CZDA, CZDB, CZDD, CZEA, CZTA, DACA, DADA, DAFA, DBWA, DDHA, DJVA, DKJA

Used equivalent to the following OE numbers:

- ▶ T10340
- ▶ T10476
- ▶ T10477
- ▶ T10494
- ▶ T10499
- ▶ T10504

9-piece



Description	Article	Price EUR*
Engine timing tool set, Audi / Seat / Škoda / VW	26400L	96.50

LOCKING TOOL CAMSHAFTS

for professional locking of the camshafts on 1.4 and 1.6 16V VAG petrol engines.

Installed in the following vehicles:

- ▶ Audi A2, 99-'05
- ▶ Seat Altea, 04-'15, Arosa, 97-'04, Cordoba, 93-'02, Cordoba, 02-'08, Ibiza, 93-'02, Ibiza, 02-'08, Ibiza, 08-'15, Inca, 95-'03, Leon, 99-'06, Leon, 05-'12, Toledo, 98-'04, Toledo, 04-'09
- ▶ Škoda Fabia, 99-'07, Fabia, 07-'14, Octavia, 96-'04, Octavia, 12-'20, Roomster, 06-'15
- ▶ VW Bora, 98-'05, Caddy, 95-'03, Caddy, 03-'15, Golf IV, 97-'03, Golf V, 03-'08, Golf VI, 08-'12, Lupo, 98-'05, New Beetle, 97-'10, Polo, 94-'01, Polo, 01-'09, Polo, 09-'14

Engine codes: AFK, AHW, AJV, AKQ, APE, AQQ, ARC, ARR, ATN, AUA, AUB, AUS, AVY, AXP, AZD, BAD, BBY, BBZ, BCA, BCB, BKY, BUD, BXW, CDDA, CGGA, CGGB, CLPA

Used equivalent to the following OE numbers:

- ▶ VAG T10016
- ▶ VAG T10074



Description	Article	Price EUR*
Locking tool camshafts	26386L	13.60

ENGINE TIMING TOOL SET, AUDI / SEAT / ŠKODA / VW

contains the most important tools for repair work on 1.4 and 1.6 l. VAG FSI, TSI and TFSI engines.

Suitable for the following vehicles:

- ▶ Audi A1, 14-18, A3, 03-13
- ▶ Seat Alhambra, 10-22, Altea, 04-15, Cordoba, 06-09, Ibiza III, 02-08, Ibiza IV, 08-15, Leon, 07-12, Toledo III, 04-09, Toledo IV, 12-19
- ▶ Škoda Fabia II, 07-14, Octavia II, 04-13, Rapid, 12-17, Roomster, 06-15, Superb II, 08-15, Yeti, 09-17
- ▶ VW Beetle, 11-19, Eos, 06-15, Golf V, 03-09, Golf VI, 08-16, Jetta III, 05-10, Jetta IV, 10-18, Passat, 05-14, CC, 12-16, Polo IV, 01-09, Polo V, 09-17, Scirocco III, 08-17, Sharan, 10-22, Tiguan, 07-18, Touran I, 10-15

Engine codes: AXU, BAG, BKG, BLF, BLG, BLN, BLP, BMY, BTS, BWK, CAVA, CAVB, CAVC, CAVD, CAVE, CAVF, CAVG, CAXA, CAXC, CDGA, CFNA, CFNB, CKMA, CLRA, CLSA, CMSA, CMSB, CNUB, CNVA, CNWA, CNWB, CTHA, CTHB, CTHC, CTHD, CTHE, CTHF, CTHG, CTJB, CTJC, CTKA

Used equivalent to the following OE numbers:

- ▶ TDC dial gauge adapter, VAG T10170A
- ▶ Locking tool camshafts, VAG T10171, T10171A, T10171B
- ▶ Locking pin crankshaft, VAG T10340
- ▶ Locking pin tensioner, VAG T40011



Audi
Seat
Škoda
VW

Description	Article	Price EUR*
Engine timing tool set, Audi / Seat / Škoda / VW	26352L	36.50

FITTING TOOL FOR BELT PULLEY, VAG

for fitting and removing the pulley on 4-cylinder 1.8l and 2.0l, 4V TFSI direct injection engines.

Suitable for the following vehicles:

- ▶ Audi: A1 (2010-), A3 (2003-2013), A3 (2012-), A4 (2007-2016), A4 (2015-), A5 (2016-), A5 Cabrio (2009-), A6 (2010-), A8 (2009-), Q2 (2016-), Q3 (2011-), Q5 (2008-2016), Q5 (2016-), Q7 (2015-), TT (2006-2014), TT (2014-)
- ▶ Seat: Alhambra (2010-), Altea (2004-), Altea XL (2006-), Ateca (2016-), Ibiza (2016-), León (2006-2012), León (2012-), Toledo (2004-2009), Toledo (2009-)
- ▶ Škoda: Kodiaq (2016-), Octavia II (2004-2013), Octavia III (2012-), Superb II (2008-2015), Superb III (2015-), Yeti (2009-)
- ▶ VW: Amarok (2010-), Arteon (2010-), Beetle (2011-), CC (2011-), EOS (2006-2015), Golf V (2003-2009), Golf VI (2008-), Golf VII (2012-), Jetta (2012-), Passat (2005-2011), Passat (2010-2014), Passat (2014-), Polo (2009-2017), Scirocco (2008-), Sharan (2010-), Tiguan (2007-2016), Tiguan (2016-), Touran (2015-), Transporter (2010-)

Engine codes:

BPU, BYT, BZB, CABA, CABB, CABD, CADA, CAEA, CAEB, CAED, CAWA, CAWB, CBFA, CCTA, CCTB, CCUA, CCZA, CCZB, CCZC, CCZD, CDAA, CDAB, CDHA, CDHB, CDNB, CDNC, CDZA, CESA, CETA, CFKA, CFPA, CGMA, CGYA, CHHA, CHHB, CHHC, CHJA, CJEB, CJED, CJEE, CJHA, CJHB, CJKA, CJKB, CJSA, CJSB, CJSC, CJXA, CJXB, CJXC, CJXD, CJXE, CJXF, CJXG, CJXH, CNCB, CNCD, CNCE, CNSB, CNTA, CNTC, CPEA, CPKA, CPLA, CPMA, CPMB, CPPA, CPRA, CPSA, CRHA, CUFA, CUHA, CUHB, CUJA, CULA, CULB, CULC, CVKB, CWNA, CWPB, CWZA, CXDA, CXDB, CYFB, CYGA, CYJA, CYMC, CYNB, CYPA, CYPB, CYRB, CYRC, CYYA, CZPA, CZPB, CZRA, DAJA, DAJB, DAXB, DAXC, DAYB, DBFB, DBPA, DBRA, DDWA, DEDA, DHGA, DJHA, DJHB, DJHC, DJJA, DLBA, DLRA

Used equivalent to OE number T10531.



Audi
Seat
Škoda
VW

Description	Article	Price EUR*
Fitting tool for belt pulley, VAG	26184L	136.90

COUNTERHOLDER CAMSHAFT AND CRANKSHAFT

Especially for counterholding camshafts, camshaft phasers and cardan shafts. Due to the enclosed screw-in adapters, this set can be used on the majority of VAG vehicles.

Suitable for the following vehicles:

- ▶ Audi: A1 (8X), A2 (8Z), A3 (8P, 8V), A4 (8E, 8K), A5 (8T), A6 (4B, 4F, 4G), A7 (4GA, 4GF), A8 (4E, 4H), Cabrio (8H), Q2 (GH), Q3 (8U), Q5 (8R), Q7 (4L, 4M), R8 (42), TT (8J, FV)
- ▶ Seat: Alhambra (710, 711), Altea (5P), Arona (KJ7), Ateca (KH7), Cordoba (6L), Exceo (3R), Ibiza (6L, 6P, KJ), Leon (1P, 5F), Mii (KF1), Toledo (5P, KG3)
- ▶ Škoda: Citigo (NF), Fabia (6Y, 54, NJ), Kodiaq (NS7), Octavia (1U, 1Z, 5E), Rapid (NH), Roomster (5J), Superb (3U, 3T, 3V), Yeti (5L)
- ▶ VW: Amarok (2H), Arteon (3H), Beetle (1Y, 5C), Bora (1J), Caddy (9K, 2C, SA), EOS (1F), Fox (5Z), Golf (1J, 1K, 5K, 5G), Jetta (AV), Passat (3C, 3G), CC (358), Phaeton (3D), Polo (9N, 6R), Scirocco (13), Sharan (7N), Tiguan (5N), Touareq (7L, 7P), Touran (1T, 5T), Transporter (7H), Up! (12), XL1

Used equivalent to the following OE numbers:

- ▶ Camshaft and crankshaft counterholder, OE number T10172
- ▶ Adapter camshaft phaser, OE number T10554



Audi
Seat
Škoda
VW

Description	Article	Price EUR*
Counterholder camshaft and crankshaft	26371L	149.50

ASSEMBLY LEVER CHAIN TENSIONER, VAG

for pushing back the chain tensioner during engine repair work, e.g. when replacing the timing chain on VAG vehicles with 4-cylinder 1.8 and 2.0 4V TFSi direct injection engines.

Engine code: BPU, BYT, BZB, CABA, CABB, CABD, CADA, CAEA, CAEB, CAED, CAWA, CAWB, CBFA, CCTA, CCTB, CCUA, CCZA, CCZB, CCZC, CCZD, CDAA, CDAB, CDHA, CDHB, CDNB, CDNC, CDND, CDZA, CESA, CETA, CFKA, CGMA, CGYA, CHHA, CHHB, CHHC, CHJA, CJEB, CJED, CJEE, CJHA, CJHB, CJKA, CJKB, CJSA, CJSB, CJSC, CJXA, CJXB, CJXC, CJXD, CJXE, CJXF, CJXG, CJXH, CNCB, CNCD, CNCE, CNSB, CNTA, CNTC, CPEA, CPKA, CPLA, CPMA, CPMB, CPPA, CPRA, CPSA, CRHA, CUFA, CUHA, CUHB, CUJA, CULA, CULB, CULC, CVJA, CVKB, CWNA, CWPB, CWZA, CXDA, CXDB, CYFB, CYGA, CYMC, CYNB, CYPA, CYPB, CYRB, CYRC, CYYA, CZPA, CZPB, CZRA, DAJA, DAJB, DAXB, DAXC, DAYB, DBFB, DBPA, DBRA, DDWA, DEDA, DHGA, DJHA, DJHB, DJHC, DJJA, DLBA, DLRA

Used equivalent to OE number T40243.



Audi
Seat
Škoda
VW

Description	Article	Price EUR*
Assembly lever chain tensioner, VAG	26174L	54.90

SCREWDRIVER BIT, 1/2", TR100 X 75 MM

With front hole



Description	Article	Price EUR*
Screwdriver bit, 1/2", TR100 x 75 mm	05389L	6.20

1/2" SPECIAL ADAPTER FOR 10 MM BITS



Description	Article	Price EUR*
1/2" Special adapter for 10 mm bits	05600L	5.50

ENGINE TIMING TOOL SET, VAG

for VAG 1.8l and 2.0l TSI / TFSI gasoline engines from ,08 with timing chain.

Fits:

- ▶ Audi A3, A4, A5, TT, Q5
- ▶ VW Eos, Golf Jetta, Passat, Scirocco, Sharan, Tiguan
- ▶ Seat Altea, Exeo, Leon, Toledo
- ▶ Skoda Octavia II, Superb II, Yeti

Engine codes:

- ▶ BYT, BZB, CABA, CABB, CABD, CAEA, CAEB, CAWA, CAWB, CBFA, CCTA, CCZA, CCZB, CCZC, CCZD, CDAA, CDAB, CDHA, CDHB, CDNB, CDNC, CDND, CESA, CETA, CFKA, CFPA, CGYA, CHHA, CJEB, CJSB, CJSB, CJSC, CPMA, CULA

Used equivalent to the following OE numbers:

- ▶ Crank counter hold tool T10355
- ▶ Crankshaft thrust piece T10368
- ▶ Drift for camshaft slide pieces T40196
- ▶ Locking clips T40267
- ▶ Camshaft clamp T40271
- ▶ Assembly tool T10352 and T10352/1



Description	Article	Price EUR*
Engine timing tool set, VAG	26159L	79.50

Audi
Seat
Skoda
VW

ENGINE TIMING TOOL SET, VAG

for professional engine servicing on 1.8 / 2.0 l FSI/TFSI/TSi 4 cylinder petrol engines, used in the following vehicles:

- ▶ Audi A1 (8X), A3 (8P), A4 (8E, 8K), A5 (8T, 8F), A6 (4F, 4G), A7 (4G), A8 (4H), Q3 (8U), Q5 (8R), TT (8J, FV)
- ▶ Seat Alhambra, Altea (5P), Exceo (3R), Leon (1P, 5F), Toledo (5P)
- ▶ Skoda Octavia (1Z, 5E), Superb (3T), Yeti (5L)
- ▶ VW Amarok (2H), Beetle (5C), CC (358), EOS (1F), Golf (1K, 5K, 5G), Jetta (1K, 16), Passat (3C, 36), Passat CC (35), Polo (6R), Scirocco (13), Sharan (7N), Tiguan (5N), Touran (1T), Transporter T5 (7H, 7E), Transporter T6 (5G, 5F)

Engine codes: BYT, BZB, CABA, CABB, CABD, CAEA, CAEB, CAED, CAWA, CAWB, CBFA, CCTA, CCTB, CCZA, CCZB, CCZC, CCZD, CDAA, CDAB, CDHA, CDHB, CDNB, CDNC, CDND, CESA, CETA, CFKA, CFPA, CGYA, CHHA, CHHB, CHHC, CHJA, CJEB, CJED, CJEE, CJK, CJKB, CJS, CJSB, CJSC, CJXA, CJXB, CJXC, CJXD, CJXE, CJXF, CJXG, CJXH, CNCB, CNCD, CNCE, CNSB, CNTA, CNTC, CPKA, CPLA, CPMA, CPMB, CPPA, CPRA, CPSA, CULA, CULB, CULC, CVKB, CVKC, CVLA, CWZA, CXCB, CXDA, CXDB, CYFB, CYGA, CYMC, CYNB, CYPA, CYPB, CYRB, CYRC, CZPA, CZPB, CZPC, DAJA, DAJB, DAXB, DAXC, DAYB, DBPA, DDWA, DEDA, DEMA, DEMB, DGUA, DGVA, DHDA, DHGA, DJHA, DJHB, DJHC, DJYA, DKNA, DKTA, DKTB, DKTC, DKYA, DKZA, DKZB, DKZC, DLBA, DLGA, DLHA, DLHB, DLRB, DLVA, DLVB, DMFA, DMFB, DMSA, DMSB, DMTA, DMTC, DNEA, DNFB, DNFC, DNFE, DNFG, DNJA, DNLA, DNNA, DNNB, DNND, DNPA, DNTA, DNUA, DNUC, DNUE, DPAA, DPUA, DPVA, DRFA, DRNB, DRXA, DRYA, DSFE, DSFF, DTEA, DUNA

Used equivalent to the following OE numbers:

- ▶ T10060A
- ▶ T10170A
- ▶ T10352
- ▶ T10352/1
- ▶ T10352/2
- ▶ T10355
- ▶ T10368
- ▶ T10567
- ▶ T40011
- ▶ T40196
- ▶ T40265
- ▶ T40266
- ▶ T40267
- ▶ T40271
- ▶ T40314
- ▶ VAS6079



Audi
Seat
Skoda
VW

Description	Article	Price EUR*
Engine timing tool set, VAG	26342L	124.50

SPECIAL SOCKET, 1/2", VAG

For loosening and tightening the camshaft adjuster mounting bolt on VAG vehicles.

Suitable for:

- ▶ Audi A1 (2010-2018), A3 (2003-2015), A4 (2000-2008), A6 (2004-2011), TT (2006-2015)
- ▶ Seat Altea (2004-2016), Exeo (2008-2014), León (2005-2013), Toledo (2004-2009)
- ▶ Skoda Octavia II (2004-2013)
- ▶ VW Eos (2006-2015), Golf V (2003-2009), Golf VI (2009-2016), Jetta (2004-2010), Passat (2005-2011), Polo (2009-), Scirocco (2008-2017), Touran (2003-2015)

Engine: AWA, AXW, AXX, BGB, BHD, BHZ, BLR, BLX, BLY, BMB, BPG, BPJ, BPY, BUL, BVX, BVY, BVZ, BWA, BWE, BWJ, BWT, BYD, BYK, BZC, CDLA, CDLB, CDLC, CDLD, CDLF, CDLG, CDLH, CDLJ, CDLK, CDMA, CRZA

Used equivalent to OE number T40080.



Audi
Seat
Skoda
VW

Description	Article	Price EUR*
Special socket, 1/2", VAG	40080L	3.40

ENGINE TIMING TOOL SET, AUDI

Contains important tools e.g. for the following work on Audi with 2.4, 3.2 and 4.2 FSI petrol engines:

- ▶ For locking the camshaft and crankshaft
- ▶ For fixing the chain tensioning unit
- ▶ For replacing the timing chain
- ▶ For adjusting the timing during engine repairs

Suitable for:

- ▶ Audi A4 (8E), A5 (8T) A6 (4F), A8 (4E), R8 (4Z)
- ▶ Enginecodes: AUK, BDW, BGP, BGQ, BKH, BNS, BPK, BSM, BTK, BVJ, BXA, BYH, BYU, CAUA

Used equivalent to The following OE numbers:

- ▶ Rotary adaptor of the crankshaft T40058
- ▶ Crankshaft fixing tool T40069
- ▶ Fixing pin for chain tensioner T40071
- ▶ 2-piece camshaft fixing tool T40070



Audi

Description	Article	Price EUR*
Engine timing tool set, Audi	26133L	50.90

ENGINE TIMING TOOL SET, AUDI / VW

for locking the camshaft and crankshaft on 2.0 FSI, TSI and TFSI VAG petrol engines

Installed in the following vehicles:

- ▶ Audi A3, 03-13, A4, 00-08, A6, 04-11, TT, 06-14
- ▶ Seat Altea, 04-15, Exeo, 08-13, Leon, 05-12, Toledo, 04-09
- ▶ Škoda Octavia, 04-13
- ▶ VW Eos, 06-15, Golf V, 03-08, Golf VI, 08-12, Jetta, 05-10, Passat, 05-10, Polo, 09-14, Scirocco, 08-17, Touran, 03-15

Engine codes: AWA, AXW, AXX, BGB, BHZ, BLR, BLX, BLY, BMB, BPG, BPJ, BPY, BUL, BVX, BVY, BVZ, BWA, BWE, BWJ, BWT, BYD, BYK, BZC, CDLA, CDLB, CDLC, CDLD, CDLF, CDLG, CDLH, CDLJ, CDLK, CDMA, CRZA

Used equivalent to the following OE numbers:

- ▶ Camshaft fixation, VAG T10252
- ▶ Adjustment tool tensioning pulley, VAG T10020
- ▶ Tensioning screw chain tensioner, VAG T10092
- ▶ Locking pin tensioning device, VAG T10060A
- ▶ Locking pin tensioning device V-ribbed belt, VAG T10115
- ▶ Chain tensioner camshaft adjuster, VAG 3366
- ▶ Locking pin tensioning pulley, VAG T40011



Audi
Seat
Škoda
VW

Description	Article	Price EUR*
Engine timing tool set, Audi / VW	26135L	62.50

CAMSHAFT ADJUSTING TOOL, 170 MM

For setting the timing on 2.3, 2.8 and 2.9 VR5 and VR6 engines.

Suitable for:

- ▶ Ford Galaxy (WGR)
- ▶ Seat Toledo II (1M)
- ▶ VW Bora (1J), Corrado (53i), Golf III (1H), Golf IV (1J), Jetta III (1K), Passat (3A), Passat (3B), Sharan (7M), Transporter T4, Vento (1H)

Engine codes AAA, ABV, AES, AGZ, AMY

Used equivalent to OE-number 3268



Description	Article	Price EUR*
Camshaft adjusting tool, 170 mm	26012L	8.90

ASSEMBLY TOOL CAMSHAFT ADJUSTMENT, VAG

removal and assembly tool for the control valve of the camshaft adjustment at Audi 1.8 I / 2.0 I TSI/TFSI 4 cylinder engines with timing chain. Suitable for the following vehicles:

- ▶ Audi A1 (2010-), A3 (2003-), A3 (2012-), A4 (2007-), A4 (2015-), A5 (2007-), A5 (2016-), A6 (2010-), A8 (2009-), Q2 (2016-), Q3 (2011-), Q5 (2008-), Q5 (2016-), Q7 (2015-), TT (2006-), TT (2014-)
- ▶ Seat Alhambra (2010-), Altea (2004-), Ateca (2016-), Exeo (2008-), Ibiza (2016-), León (2005-), León (2012-), Toledo (2004-), Toledo (2009-)
- ▶ Skoda Kodiak (2016-), Octavia II (2004-), Octavia III (2012-), Superb II (2008-), Superb III (2015-), Yeti (2009-)
- ▶ VW Amarok (2010-), Arteon (2017-), Beetle (2011-), CC (2011-), EOS (2006-), Golf V (2003-), Golf VI (2008-), Golf VII (2012-), Jetta (2009-), Passat (2005-), Passat (2010-), Passat (2014-), Polo (2009-), Scirocco (2008-), Sharan (2010-), Tiguan (2007-), Tiguan (2016-), Touran (2015-), Transporter T5 (2003-), Transporter T6 (2015-)

Engine codes:

BPU, BYT, BZB, CABA, CABB, CABD, CADA, CAEA, CAEB, CAED, CAWA, CAWB, CBFA, CCTA, CCTB, CCUA, CCZA, CCZB, CCZC, CCZD, CDA, CDAB, CDHA, CDHB, CDNB, CDNC, CDND, CDZA, CESA, CETA, CFKA, CFPA, CGMA, CGYA, CHHA, CHHB, CHHC, CHJA, CJEB, CJED, CJEE, CJHA, CJHB, CJKA, CJKB, CJSA, CJSB, CJSC, CJXA, CJXB, CJXC, CJXD, CJXE, CJXF, CJXG, CJXH, CNCB, CNCD, CNCE, CNSE, CNTA, CNTC, CPEA, CPKA, CPLA, CPMA, CPMB, CPPA, CPRA, CPSA, CRHA, CUFA, CUHA, CUHB, CUJA, CULA, CULB, CULC, CVJA, CVKB, CWNA, CWPB, CWZA, CXDA, CXDB, CYFB, CYGA, CYMC, CYNB, CYPA, CYPB, CYRB, CYRC, CYVA, CZPA, CZPB, CZRA, DAJA, DAJB, DAXB, DAXC, DAYB, DBFB, DBPA, DBRA, DDWA, DEDA, DHGA, DJHA, DJHB, DJHC, DJJA, DLBA, DLRA

Uses equivalent to the following OE numbers:

- ▶ T10352
- ▶ T10352/1A
- ▶ T10352/2
- ▶ T10352/3
- ▶ T10352/4
- ▶ T10352C



Audi
Seat
Škoda
VW

Description	Article	Price EUR*
Assembly tool camshaft adjustment, VAG	26340L	22.50

CAMSHAFT LOCKING TOOL, AUDI / VW

Tool bracket for fixing the camshaft sprockets of V-engines. For work on the motor control unit e.g. timing belt work. The bracket can be moved so that both 4-valve and 5-valve engines can be served using the one tool. This avoids additional costs.

Can be used with:

- ▶ Audi 80 (91-95), 100 (90-94), A4 (94-02), A6 (94-97), A6 (97-05), A6 (04-11), A8 (94-05), A8 (02-10), Cabriolet (91-00), Coupé (88-96)
- ▶ Skoda Superb (01-08)
- ▶ VW Passat (96-05), Phaeton (02-16), Touareg (02-13)

Engine codes: AAH, ABC, ACK, ACZ, AEJ, AGA, AGB, AGE, AHA, AJG, AJK, AKB, AKC, ALF, ALG, ALW, AML, AMM, AMX, ANK, APB, APC, APR, APS, APZ, AQD, AQF, AQG, AQH, AQJ, ARE, ARJ, ARN, ARS, ART, ARU, ASG, ASJ, ASM, ATQ, ATX, AUW, AUX, AVN, AVP, AWA, AXQ, AYS, AZA, AZB, AZR, BBD, BBG, BCS, BCY, BDV, BEL, BES, BFL, BFM, BGH, BGJ, BGK, BHX, BRV

Used equivalent to the following OE numbers:

- ▶ VAG 3243
- ▶ VAG 3391
- ▶ T30065
- ▶ T40005



Audi
Škoda
VW

Description	Article	Price EUR*
Camshaft locking tool, Audi / VW	27001L	67.90

CAMSHAFT TURNING TOOL, VAG

the camshaft turning tool is used equivalent to OE number T10567 and at the same time replaces OE T40266.

Suitable for the following vehicles:

- ▶ Audi A1 (8X) 2011-; A3 (8V) 2013-; A4 (8K) 2008-; A4 (8W) 2015-; A5 (8T/8F) 2008-; A5 (F5) 2016-; A6 (4G) 2011-; A8 (4H) 2010-; Q2 (GAB) 2016-; Q3 (8U) 2012-; Q5 (8RB) 2008-; Q7 (4MB) 2016-; TT (8J) 2007-; TT (FV) 2015-
- ▶ Seat Alhambra (7N) 2015-; Ibiza (KJ1) 2016-; Leon (5F) 2013-; Ateca (KH7) 2017-
- ▶ Skoda Kodiaq (NS7) 2017-; Octavia III (5E) 2013-; Superb III (3V) 2015-
- ▶ VW Arteon (3H7) 2018-; Beetle (5C) 2012-; Golf VII (5G/BE/BA) 2013-; Jetta IV (16) 2010-; Passat (3G) 2014-; Polo (6R) 2014-; Scirocco (13) 2015-; Sharan (7N) 2016-; Tiguan (AD) 2016-; Touran (5T) 2015-; Transporter (T5) 2010-; Transporter (T6) 2015-

Engine codes:

BPU; BYT; BZB; CABA; CABB; CABD; CADA; CAEA; CAEB; CAED; CAWB; CBFA; CCTA; CCUA; CCZA; CCZC; CDHA; CDHB; CDNB; CDNC; CDZA; CESA; CETA; CFKA; CGMA; CHHA; CHHB; CHHC; CHJA; CJEB; CJED; CJEE; CJHA; CJHB; CJKA; CJKB; CJSB; CJSB; CJSB; CJSC; CJXA; CJXB; CJXC; CJXD; CJXE; CJXF; CJXG; CJXH; CNCB; CNCD; CNCE; CNSB; CNTA; CNTC; CPEA; CPKA; CPLA; CPMA; CPMB; CPPA; CPRA; CPSA; CRHA; CUFA; CUHA; CUHB; CUJA; CULA; CULB; CULC; CVJA; CVKB; CWNA; CWPB; CWZA; CXDA; CXDB; CYFB; CYGA; CYMC; CYNB; CYPB; CYPB; CYRB; CYRC; CYRA; CYRA; CZPA; CZPB; CZRA; DAJA; DAJB; DAXB; DAXC; DAYB; DBFB; DBPA; DBRA; DCAA; DDWA; DEDA; DHGA; DJHA; DJHB; DJHC; DJJA; DLBA; DLRA



Audi
Seat
Škoda
VW

Description	Article	Price EUR*
Camshaft turning tool, VAG	94901L	10.40

ENGINE TIMING TOOL SET, AUDI / FORD / SEAT / ŠKODA / VW

contains the most important tools for changing the timing belt on 1.2, 1.4 and 1.9 l. VAG TDI engines. For vehicles with round crankshaft sprocket.

Suitable for the following vehicles:

- ▶ Audi A2, 99-05, A3, 96-03, A4, 94-01, A4, 00-08, A6, 97-05
- ▶ Ford Galaxy I 95-10
- ▶ Seat Alhambra I, 95-10, Arosa, 97-04, Cordoba, 02-08, Ibiza III, 02-08, Ibiza IV, 08-17, Leon, 99-09, Toledo II, 98-04
- ▶ Škoda Fabia I, 99-07, Fabia II, 07-14, Octavia I, 96-00, Roomster, 06-10, Superb I, 01-08
- ▶ VW Bora I, 98-05, Fox, 05-11, Golf IV, 98-06, Lupo, 98-05, New Beetle, 97-10, Passat IV, 96-05, Polo III, 94-01, Polo IV, 01-09, Sharan I, 95-10

Engine codes: AJM, AMF, ANU, ANY, ARL, ASZ, ATD, ATJ, ATL, AUJ, AVB, AVF, AWX, AXR, AYZ, BAY, BEW, BHC, BLT, BMS, BNM, BNV, BSW, BTB, BWB

Used equivalent to the following OE numbers:

- ▶ Locking tool crankshaft, VAG T10050, Ford 310-085
- ▶ Locking pin camshaft/fuel pump, VAG 3359
- ▶ Locking plate tensioner, VAG T10008, Ford 310-084



Audi
Ford
Seat
Škoda
VW

Description	Article	Price EUR*
Engine timing tool set, Audi / Ford / Seat / Škoda / VW	26353L	9.00

ENGINE TIMING TOOL SET, AUDI / SEAT / ŠKODA / VW

contains the most important tools for repair work on 1.9 and 2.0 l. VAG TDI engines. For vehicles with oval crankshaft sprocket.

Suitable for the following vehicles:

- ▶ Audi A4, 00-08
- ▶ Seat Alhambra, 95-10
- ▶ Škoda Superb, 01-08
- ▶ VW Sharan, 95-10

Engine codes: BKE, BPW, BPZ, BRB, BRC, BSV, BVK

Used equivalent to the following OE numbers:

- ▶ Locking tool crankshaft, VAG T10100
- ▶ Locking pin camshaft/fuel pump, VAG 3359
- ▶ Locking plate tensioner, VAG T10008



Audi
Seat
Škoda
VW

Description	Article	Price EUR*
Engine timing tool set, Audi / Seat / Škoda / VW	26356L	8.50

ENGINE TIMING TOOL SET, AUDI / SEAT / ŠKODA / VW

contains the most important tools for repair work on 1.2, 1.5, 1.6, 1.9 and 2.0 l. VAG TDI engines.

Suitable for the following vehicles:

- ▶ Audi A1, A3 (8P), A4 (B8), A5, A6, (C6, C7), TT (8J), Q3, Q5
- ▶ Seat Ibiza (6J), Leon III, Exeo, Toledo, Altea, Alhambra II
- ▶ Škoda Fabia II, Roomster, Praktik, Octavia II, Superb II, Yeti
- ▶ VW Amarok, Beetle II, Caddy II, Eos, Golf V/VI/Plus, Jetta V/VI, Passat B6/B7/CC, Polo V, Scirocco III, Sharan II, Touran II, Tiguan, T5

Engine codes: AVQ, AXB, AXC, AZV, BDJ, BDK, BEE, BGW, BHW, BJB, BKC, BKD, BKP, BLB, BLS, BMA, BMM, BMN, BMP, BMR, BMT, BNA, BPX, BRD, BRE, BRF, BRR, BRS, BRT, BRU, BSS, BST, BSU, BUK, BUY, BUZ, BVA, BVE, BVF, BVG, BVH, BWC, BWV, BXE, BXF, BXJ, CAAA, CAAB, CAAC, CAAD, CAAE, CAGA, CAGB, CAGC, CAHA, CAHB, CAYA, CAYB, CAYC, CAYD, CAYE, CBAA, CBAB, CBAC, CBBA, CBBC, CBDA, CBDB, CBDC, CBEA, CCHA, CCHB, CDBA, CDCA, CEGA, CFCA, CFFA, CFFB, CFFD, CFFE, CFGB, CFGC, CFGD, CFHA, CFHB, CFHC, CFHD, CFHE, CFHF, CFJA, CFJB, CFWA, CGLA, CGLB, CGLC, CGLD, CGLE, CJAA, CJCA, CJCB, CJCC, CJCD, CLCA, CLCB, CLJA, CLLA, CLLB, CLNA, CMEA, CMFA, CMFB, CMGA, CMGB, CNEA, CNFA, CNFB, CSHA, CUVB, DDCA, DFSA, DFTB, DFTC

Used equivalent to the following OE numbers:

- ▶ Locking pin camshaft/fuel pump, VAG 3359
- ▶ Locking tool crankshaft, VAG T10050
- ▶ Locking tool crankshaft (oval crankshaft sprocket), VAG T10100
- ▶ Puller camshaft sprocket, VAG T10052
- ▶ Counterholder fuel pump wheel, VAG T10051A
- ▶ Locking tool balance shafts, VAG T10255
- ▶ Locking pin tensioner, VAG T10265
- ▶ Locking pin tensioner V-ribbed belt, VAG T10060A
- ▶ Adjusting tool tensioner, 6 mm, VAG T10264



Audi
Seat
Škoda
VW

Description	Article	Price EUR*
Engine timing tool set, Audi / Seat / Škoda / VW	26357L	67.90

ENGINE TIMING TOOL SET, AUDI / SEAT / ŠKODA / VW

contains the most important tools for repair work on 1.6 and 2.0 l. VAG TDI common-rail engines.

Suitable for the following vehicles:

- ▶ Audi A1,14-18, A3,12-20, A3,20-, A4,07-15, A4,15-, A5,07-16, A5,16-, A6,11-18, A6,18-, A7,18-, Q2,16-, Q3,11-18, Q3,18-, Q5,08-17, Q5,17-, TT,14-19
- ▶ Cupra Formentor,21-
- ▶ MAN TGE,16-
- ▶ Seat Alhambra,10-22, Arona,17-, Ateca,16-, Ibiza IV,08-17, Ibiza V,17-, Leon III,12-20, Leon IV,20-, Tarraco,18-, Toledo IV,12-19
- ▶ Škoda Fabia III,14-22, Kamiq,19-, Karoq,17-, Kodiaq,16-, Octavia III,12-20, Octavia IV,20-, Rapid,12-19, Scala,19-, Superb III,15-, Yeti,09-17
- ▶ VW Arteon,17-, Beetle,11-19, Caddy IV,03-20, Caddy V,20-, Golf VII,12-20, Golf VIII,19-, Jetta IV,10-18, CC,12-16, Passat VIII,14-19, Polo V,09-17, Scirocco,08-17, Sharan,10-22, Tiguan I,07-18, Tiguan II,16-, Touran II,15-, T-Cross,18-, T-Rock,17-, Crafter I,06-16, Crafter II,16-, Transporter T6,15-21, Transporter T7,21-

Engine codes: CKFB, CKFC, KCTB, CKTC, CKUB, CKUC, CLHA, CLHB, CNHA, CNHC, CRBB, CRBC, CRBD, CRFA, CRFC, CRGB, CRKA, CRKB, CRLB, CRLC, CRLD, CRMB, CRUA, CRVA, CRVC, CSLA, CSLB, CSLC, CSNA, CSUA, CSUB, CSUD, CSUE, CUA, CUNA, CUPA, CUSA, CUSB, CUTA, CUUA, CUUB, CUUD, CUUE, CUUF, CUVA, CUVC, CUVD, CUVE, CUWA, CUXA, CVCA, CXEB, CXEC, CXFA, CXGA, CXGB, CXGD, CXHA, CXHB, CXHC, CXMA, CXXA, CXXB, CYKA, CYKB, CYKC, CYLA, CYZA, CYZB, CZHA, CZJA, DASA, DASB, DASC, DAUA, DAUB, DAVA, DAWA, DBBA, DBGA, DBGB, DBGC, DBKA, DCXA, DCYA, DCYB, DCZA, DDA, DDCB, DDDA, DDYA, DDYB, DEJA, DEJB, DELA, DESA, DETA, DETB, DEUA, DEUB, DEUC, DEZB, DEZD, DEZE, DEZF, DFBA, DFCA, DFEA, DFEB, DFFA, DFGA, DFGB, DFGC, DFHA, DFLA, DFLD, DFMA, DFSB, DFSC, DFSD, DFSE, DFSF, DFTA, DFUA, DFVA, DGCA, DGDA, DGDB, DGMA, DGTA, DGTC, DGTD, DGTE, DJGA, DLTA, DLTC, DLUB, DMZA, DMZB, DNAA, DNAB, DNAC, DNAD, DNAS, DSRA, DSRB, DSSA, DSTA, DSTB, DSUB, DSUD, DTNA, DTNB, DTPA, DTPB, DTRA, DTRB, DTRC, DTRD, DTRE, DTRF, DTTA, DTSB, DTTA, DTTC, DTUA

Used equivalent to the following OE numbers:

- ▶ Fixing tool crankshaft, VAG T10490
- ▶ Counterholder fuel pump wheel, VAG T10051
- ▶ Locking pin tensioner V-ribbed belt, VAG T10060A
- ▶ Adjusting tool tensioner, 6 mm, VAG T10264
- ▶ Locking pin tensioner, VAG T10265
- ▶ 2x Locking pin camshaft/fuel pump, VAG T10492
- ▶ 2x Locking pin camshaft/fuel pump, VAG 3359



Audi
MAN
Seat
Škoda
VW

Description	Article	Price EUR*
Engine timing tool set, Audi / Seat / Škoda / VW	26365L	102.90

ENGINE TIMING TOOL SET, AUDI / VW

contains important tools, e.g. for the following work on VW / Audi 2.7 l and 3.0 l V6 diesel engines.

- ▶ To lock the camshaft and crankshaft
- ▶ To lock the balance shaft
- ▶ To fasten the chain tensioner unit
- ▶ To replace the timing chain
- ▶ To set the timing during engine repairs

Suitable for:

- ▶ Audi A4, A5, A6, A8, Q5, Q7
- ▶ VW Touareg, Phaeton
- ▶ With Motor Codes: ASB, ASE, BKN, BKS, BMC, BMK, BMZ, BNG, BPP, BSG, BTR, BUG, BUN, BVN, CAMA, CAMB, CANA, CANB, CANC, CAND, CAPA, CARA, CARB, CASA, CASB, CASC, CATA, CCF, CCFB, CCFD, CCFE, CCFG, CCHA, CCMA, CCWA, CCWB, CDSB, CTEC, CDYA, CDYB, CDYC, CEXA, CGKA, CGKB

Used equivalent to the following OE numbers:

- ▶ Adapter to tension the sprocket T40062
- ▶ Adapter to correct the camshaft setting T40061
- ▶ Swivel adapter for the crankshaft T40049
- ▶ Peg for the injector pump 3359 / T20102
- ▶ Swivel adapter for the crankshaft T40058
- ▶ 2 x camshaft retainers T40060
- ▶ Crankshaft peg 3242



Audi
VW

Description	Article	Price EUR*
Engine timing tool set, Audi / VW	26337L	96.50

ENGINE TIMING TOOL SET, AUDI/VW

suitable for 3.0 l TDI V6 diesel engines, used in the following Audi and VW vehicles:

- ▶ Audi A4 (8K), A5 (8F, 8T), A6 (4G), A7 (4G), A8 (4H), Q5 (8R), Q7 (4L)
- ▶ VW Touareg (7P)

Engine codes:

CDTA, CDTB, CDTC, CDUC, CDUD, CGQB, CJGA, CJGC, CJGD, CJMA, CKDA, CKVB, CKVC, CKVD, CLAA, CLAB, CLZB, CMHA, CNRB, CPNA, CPNB, CRCA, CRCD, CTBA, CTBB, CTBC, CTBD, CTCB, CTCC, CVUA, CVUB, CVUC, CVVA, CVWA, DEHA

Used equivalent to the following OE numbers:

- ▶ T10060A
- ▶ T20102 / 3359
- ▶ T20167
- ▶ T30052
- ▶ T40049
- ▶ T40058
- ▶ T40060
- ▶ T40062
- ▶ T40071
- ▶ T40237 / 3242
- ▶ T40245
- ▶ T40257
- ▶ T40314
- ▶ T40316



Audi
VW

Description	Article	Price EUR*
Engine timing tool set, Audi/VW	26345L	119.90

LOCKING PLATE TENSIONER

for locking the timing belt tensioner on TDI PD engines from Audi, Ford, Seat and VW

number:

- ▶ Audi/VW T10008
- ▶ Ford 23-058
- ▶ Ford 310-084

Used equivalent to the following OE



Audi
Ford
Seat
Škoda
VW

Description	Article	Price EUR*
Locking plate tensioner	26366L	4.40

CAMSHAFT ASSEMBLY TOOL SET, AUDI / VW

This tool serves for the positioning and installation of the camshafts in the camshaft module. Before the installation of the camshaft module, the positioning and fixing of the camshafts with respect to each other are absolutely necessary. Otherwise the guide bearings in the cylinder head are destroyed and the cylinder head must be renewed.

Necessary in case of diesel engines 1.2/1.5/1.6/2.0/2.7/3.0/4.0/4.2 TDI with 4-valve technology.

Suitable for:

- ▶ Audi A1 (2010-2018), A3 (2003-2015), A4 (2000-2009), A4 (2007-2016), A5 (2007-2017), A6 (2004-2011), A6 (2010-2018), A8 (2002-2010), A8 (2009-2018), Q3 (2011-), Q5 (2008-), Q7 (2006-2016), TT (2006-2015)
- ▶ Seat Alhambra (2010-), Altea (2004-), Exeo (2008-), Ibiza IV (2008-2017), Leon (2005-2013), Toledo III (2004-2009), Toledo IV (2012-2019)
- ▶ Skoda Fabia II (2006-2014), Octavia II (2004-2013), Rapid (2012-), Roomster (2006-2015), Superb II (2008-2015), Yeti (2009-2017)
- ▶ VW Amarok (2010-), Beetle (2011-), Caddy III (2004-2015), Caddy IV (2015-), EOS (2006-2015), Golf VI (2008-2016), Golf Plus (2004-2013), Jetta III (2004-2010), Jetta IV (2008-), Passat (2005-2011), Passat CC (2008-2012), Passat (2010-2015), CC (2011-2016), Phaeton (2002-2016), Polo (2009-), Scirocco (2008-2017), Sharan (2010-), Tiguan (2007-2018), Touareg (2002-2013), Touareg (2010-2018), Crafter (2006-2016), Transporter T5 (2003-2015), Transporter T6 (2015-)

Engine codes:

ASB, ASE, BKN, BKS, BMC, BMK, BNG, BPP, BSG, BTR, BUG, BUN, BVN, CAAA, CAAB, CAAC, CAAD, CAAE, CAGA, CAGB, CAGC, CAHA, CAHB, CAMA, CAMB, CANA, CANB, CANC, CAND, CAPA, CARA, CASA, CASB, CASC, CASD, CATA, CAYA, CAYB, CAYC, CAYD, CAYE, CBAA, CBAB, CBAC, CBBA, CBBB, CBDA, CBDB, CBDC, CBEA, CCFA, CCFB, CCHA, CCHB, CCLA, CCMA, CCWA, CCWB, CDBA, CDCA, CDSB, CDYA, CDYB, CDYC, CEGB, CEXA, CEXB, CFCA, CFFA, CFFB, CFFD, CFFE, CFGB, CFGC, CFGD, CFHA, CFHB, CFHC, CFHD, CFHE, CFHF, CFJA, CFJB, CFWA, CGKA, CGKB, CGLA, CGLB, CGLC, CGLD, CGLE, CJAA, CJCA, CJCB, CJCC, CJCD, CKDA, KCTB, CKTC, CKUB, CKUC, CLCA, CLCB, CLCC, CLCD, CLJA, CLLA, CLLB, CLNA, CMEA, CMFA, CMFB, CMGA, CMGB, CNEA, CNEB, CNFA, CNFB, CSHA, CSLA, CSLB, CSLC, CSNA, CTEC, CWXB, CWXC

Used equivalent to the following OE numbers:

- ▶ T40094
- ▶ T40095
- ▶ T40096

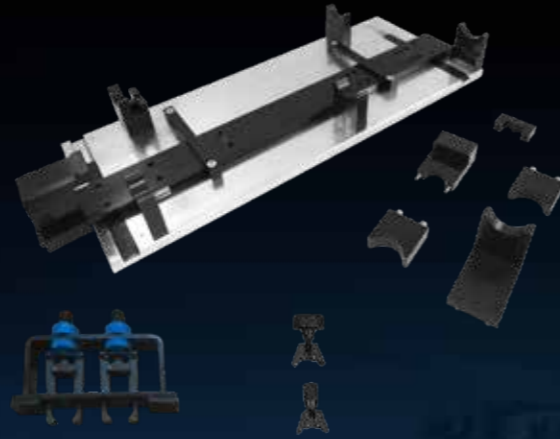

Audi
Seat
Škoda
VW

Description	Article	Price EUR*
Camshaft assembly tool set, Audi / VW	26154L	509.90

LOCKING TOOL CRANKSHAFT

for professional locking of the crankshaft in TDC position during timing and engine repairs

Used equivalent to the following OE number:

- ▶ Ford 23-059
- ▶ Ford 310-085
- ▶ Audi/VW T10050



Audi
Ford
Seat
Škoda
VW

Description	Article	Price EUR*
Locking tool crankshaft	26368L	6.80

LOCKING TOOL CRANKSHAFT

for professional locking of the crankshaft in TDC position during timing and engine repairs

Used equivalent to the following OE number:

- ▶ Mitsubishi MB-995209
- ▶ Audi/VW T10100



Audi
Seat
Škoda
VW

Description	Article	Price EUR*
Locking tool crankshaft	26369L	11.30

LOCKING PIN CAMSHAFT / FUEL PUMP

for locking the injection pump sprocket on TDI engines without PD as well as for positioning the camshaft on PD engines from Audi, Seat, Škoda, VW and Ford

Used equivalent to the following OE numbers:

- ▶ Audi/VW 3359
- ▶ Mitsubishi MB-995206
- ▶ Seat T20102
- ▶ Škoda MP1-301
- ▶ Škoda U40074



Audi
Ford
Mitsubishi
Seat
Škoda
VW

Description	Article	Price EUR*
Locking pin camshaft / fuel pump	26367L	5.60

TENSIONER SPANNER TOOL, VAG

Used equivalent to the following OE numbers:

- ▶ VM-9660
- ▶ 303-1053
- ▶ U30009
- ▶ MP1-302
- ▶ V/159



Audi
Seat
Škoda
VW

Description	Article	Price EUR*
Tensioner spanner tool, VAG	10550L	9.00

ADJUSTING TOOL TENSIONER, VAG

for professional rotating of the tensioning pulley during timing drive and engine repairs. 5-position adjustable and up to 180° rotatable handle. This allows the tool to be used without problems even with tensioners that are difficult to reach.

Used equivalent to the following OE number:

- ▶ VAG 3387



Audi
Škoda
VW

Description	Article	Price EUR*
Adjusting tool tensioner, VAG	26385L	10.80

FLYWHEEL LOCKING TOOL, VAG

for locking the flywheel during repair work on the clutch or on the timing belt of Seat, Skoda and VW vehicles.

Suitable for the following vehicles:

- ▶ Seat Alhambra (2010-), Altea (2004-), Cordoba (2002-2009), Ibiza III (2002-2009), Ibiza IV (2008-2017), Leon I (1999-2006), Leon II (2005-2013), Toledo II (1998-2006), Toledo III (2004-2009), Toledo IV (2012-)
- ▶ Skoda Fabia II (2006-2014), Superb II (2008-2015)
- ▶ VW Beetle (1998-2011), Beetle (2011-), Bora (1998-2005), Caddy III (2004-2015), CC (2011-2016), Eos (2006-2015), Golf IV (1997-2007), Golf V (2003-2009), Golf VI (2008-2013), Jetta III (2004-2010), Jetta IV (2009-), Lupo (1998-2005), Passat (2005-2011), Passat (2011-2014), Phaeton (2002-2016), Polo (2001-2012), Polo (2009-), Scirocco (2008-2017), Sharan (2010-), Tiguan (2007-2016), Touareg (2002-2015), Touareg (2015-), Touran (2003-2010), Transporter T5 (2003-2015)

Engine codes:

AHT, AQP, ASY, AUE, AXB, AXC, AXJ, AXU, AXZ, AYT, BAG, BDE, BDL, BFH, BHK, BHL, BJS, BKG, BKK, BKL, BLF, BLG, BLN, BLP, BLV, BML, BMY, BRK, BRR, BRS, BTS, BUB, BWK, BWS, CAVA, CAVB, CAVC, CAVD, CAVE, CAVF, CAXA, CAXC, CBRA, CBZA, CBZB, CBZC, CDGA, CDVA, CFNA, CGRA, CKMA, CMSB, CMTA, CNKA, CNNA, CNUB, CNWA, CTHA, CTHB, CTHC, CTHD, CTHE, CTHF, CTJB, CTJC, CTKA

Used equivalent to OE number T10044.



Seat
Škoda
VW

Description	Article	Price EUR*
Flywheel locking tool, VAG	26309L	54.50

COUNTERHOLDER, VAG

for VW 1.4 - 1.6 and 2.0 I engines.

- ▶ For counterholding the crankshaft pulley on 4-valve engines with pin diameter 11.5 mm
- ▶ For counterholding the crankshaft timing belt sprocket on 2-valve engines
- ▶ M8 bolt

Suitable for:

- ▶ Audi A2, A3, A4, A5, TT
- ▶ Skoda Fabia, Octavia, Superb
- ▶ VW Bora, Caddy, Golf, Lupo, New Beetle, Polo, Sharan, Touran, Transporter

Engine codes: ADX, AEA, AEE, AEH, AEX, AFH, AFK, AGP, AGR, AHW, AJM, AKL, ALN, AMF, ANA, ANY, APE, APE, APF, ARM, ATJ, AUA, AWH, CGGA, CGPB

Used equivalent to the following OE numbers:

- ▶ T30004
- ▶ 3415



Audi
Seat
Skoda
VW

Description	Article	Price EUR*
Counterholder, VAG	10586L	35.50

COUNTERHOLDER CRANKSHAFT, VAG

For crankshaft pulley when loosening and tightening the central bolt on VW 1.6I engines

- ▶ VW Bora, Golf, Lupo, New Beetle, Polo, Caddy
- ▶ Seat Ibiza, Cordoba
- ▶ For engine codes: ARC, ATN, AUS, AVY, AZD, BCB



Seat
VW

Description	Article	Price EUR*
Counterholder crankshaft, VAG	10584L	32.50

ENGINE TIMING TOOL SET, PORSCHE

contains important tools for the installation and removal of the camshaft, for testing and adjusting the valve timing as well as for timing chain repairs on all Porsche MA1 engines.

Suitable for the following vehicles:

- ▶ Porsche: 911 type 911 / 911 type 997 / Boxster type 987 / Boxster type 981 / Cayman type 987 / Cayman type 981

Used equivalent to the following OE numbers:

- ▶ Camshaft installation tool equivalent to OE 9772
- ▶ Camshaft holding tool equivalent to OE 9775
- ▶ Crankshaft fixing pin equivalent to OE 9595/1
- ▶ Turning tool for belt pulley equivalent to OE 9773



Porsche

Description	Article	Price EUR*
Engine timing tool set, Porsche	26177L	283.00

ENGINE TIMING TOOL SET, MERCEDES-BENZ

for locking crankshaft and camshaft on Mercedes-Benz petrol and diesel engines and identical engines in Chrysler PT Cruiser 2.2I CRD, Jeep Grand Cherokee 2.7 CRD etc.

- ▶ Petrol 1.8 / 2.0 / 2.2 / 2.3 / 2.5, M102 und M111
- ▶ Diesel 2.1 / 2.2 / 2.7 / 3.0 / 3.3, OM611, OM612, OM613, OM646

Used equivalent to the following OE numbers:

- ▶ Crankshaft locking tool inc. 2 bolts M6x90 / 601 589 02 40 00
- ▶ Crankshaft locking tool / 602 589 00 40 00
- ▶ Camshaft locking pins / 111 589 03 15 00



Chrysler
Jeep
Mercedes-Benz

Description	Article	Price EUR*
Engine timing tool set, Mercedes-Benz	26333L	56.50

ENGINE TIMING TOOL SET, MERCEDES-BENZ

for locking crankshaft and camshaft on Mercedes-Benz petrol and diesel engines and identical engines in Chrysler PT Cruiser 2.2I CRD, Jeep Grand Cherokee 2.7 CRD etc.

- ▶ Petrol 1.8 / 2.0 / 2.2 / 2.3 / 2.5, M102 und M111
- ▶ Diesel 2.1 / 2.2 / 2.7 / 3.0 / 3.3, OM611, OM612, OM613, OM646

Used equivalent to the following OE numbers:

- ▶ Crankshaft locking tool inc. 2 bolts M6x90 / 601 589 02 40 00
- ▶ Crankshaft locking tool / 602 589 00 40 00
- ▶ Camshaft locking pins / 111 589 03 15 00



Chrysler
Jeep
Mercedes-Benz

Description	Article	Price EUR*
Engine timing tool set, Mercedes-Benz	26044L	51.50

ENGINE TIMING TOOL SET, MERCEDES-BENZ

contains the most important tools for repair work on 1.6 and 1.8 I. Mercedes-Benz petrol engines.

Suitable for the following vehicles:

- ▶ Mercedes-Benz: C-Klasse ,00-'07, C-Klasse ,07-'15, CLK ,03-'10, E-Klasse ,02-'09, E-Klasse ,09-'17, SLK ,04-'11, SLK ,11-'20 und Sprinter ,06-'18

Engine codes: M271.820, M271.860, M271.861, M271.910, M271.911, M271.921, M271.940, M271.941, M271.942, M271.944, M271.946, M271.948, M271.950, M271.951, M271.952, M271.954, M271.955, M271.956, M271.957, M271.958

Used equivalent to the following OE numbers:

- ▶ Retainer timing chain, Mercedes 271 589 01 40 00
- ▶ Locking tool camshafts, Mercedes 271 589 00 61 00
- ▶ Locking tool chain tensioner, Mercedes 271 589 00 15 00
- ▶ Wedge slide rails, Mercedes 271 589 00 31 00



Mercedes-Benz

Description	Article	Price EUR*
Engine timing tool set, Mercedes-Benz	26364L	124.50

ENGINE TIMING TOOL SET, MERCEDES-BENZ



for 1.8l / 2.2l four-cylinder Mercedes-Benz Diesel engines from '08 with timing chain and engine code OM 651. Contains two camshaft locking devices and one crankshaft belt pulley locking device. For setting the engine timing e.g. during replacement of the timing chain or during engine repairs.

Suitable for: A180 / A200 / A220 CDI / Blue Efficiency (W176), B180 / B200 / B220 CDI / Blue Efficiency (W246), C180 / C200 / C220 CDI / Blue Efficiency (W/S/C 204), CLA200 / CLA220 (C117), E200 CDI / Blue Efficiency / BlueTec (W/S 212), GLA200 / GLA220 CDI (X156), GLK200 CDI Blue Efficiency (X204), Sprinter 210 / 213 / 216 / 310 / 313 / 316 / 413 / 416 / 510 / 513 / 516 CDI / BlueTec (W906), Vito110 / T13 / T16, Viano 2.0 / 2.2 CDI (W/V639), Vito T14 / T16 CDI, V200 / V220 CDI (W/V447)

Used equivalent to the following Mercedes-Benz OE numbers:

- ▶ 651 589 09 40 00 camshaft locking device
- ▶ 651 589 00 40 00 crankshaft belt pulley locking device



Mercedes-Benz

Description	Article	Price EUR*
Engine timing tool set, Mercedes-Benz	26185L	84.90

TIMING CHAIN TOOL SET, MERCEDES-BENZ



special tool for separating and riveting the timing chains of gasoline and diesel engines with single and double timing chain on Mercedes-Benz vehicles.

Used equivalent to the following OE numbers:

- ▶ 103 589 01 63 00
- ▶ 112 589 04 63 01
- ▶ 112 589 06 93 00
- ▶ 602 589 00 39 00
- ▶ 602 589 02 33 00
- ▶ 602 589 02 40 00
- ▶ 602 589 02 63 00
- ▶ 602 589 03 63 00
- ▶ 602 589 04 63 00



Mercedes-Benz

Description	Article	Price EUR*
Timing chain tool set, Mercedes-Benz	26330L	147.00

ENGINE TIMING TOOL SET, BMW



Contains important tools e.g. for the following tasks on petrol engines M40, M43 as well as engines with double camshafts M42, M44, M50, M52, M54, M56:

- ▶ Installing and removing as well as adjusting the camshaft unit
- ▶ Checking and setting the engine timing
- ▶ Changing the timing belt and timing chain



BMW

Description	Article	Price EUR*
Engine timing tool set, BMW	26103L	192.50

TIMING CHAIN TESTING TOOL, BMW / MINI



allows testing of the chain elongation on BMW and Mini petrol engines with 1.4 and 1.6 l capacity as well as diesel engines with 1.6 and 2.0 l capacity. The test is carried out by replacing the installed chain tensioner with this tool. A possible elongation is directly readable.

Suitable for the following vehicles:

- ▶ Alpine D3 E90 / E91 / E92
- ▶ BMW series 1 E81 / E82 / E87 / E88 / F20 / F21
- ▶ BMW series 2 F22 / F87
- ▶ BMW series 3 E90 / E91 / E92 / E93 / F30 / F31 / F34 / F35 / F80
- ▶ BMW series 4 F32 / F33 / F36 / F82 / F83
- ▶ BMW series 5 E60 / E61 / F07 / F10 / F11
- ▶ BMW series X1 E84
- ▶ BMW series X3 E83 / F25
- ▶ BMW series X5 F15 / F85
- ▶ Mini R55 Clubman
- ▶ Mini R56
- ▶ Mini R57 Cabriolet
- ▶ Mini R58 Coupe
- ▶ Mini R59 Roadster
- ▶ Mini R60 Countryman
- ▶ Mini R61 Paceman

Engine codes: N12, N13, N14, N16, N18, N47

Used equivalent to OE number 2 353 281.



BMW
Mini

Description	Article	Price EUR*
Timing chain testing tool, BMW / Mini	26311L	11.30

ENGINE TIMING TOOL SET, CITROËN / MINI / PEUGEOT

for locking the camshaft and crankshaft on 1.4 and 1.6 petrol engines

Installed in the following vehicles:

- ▶ Citroën Berlingo, 08-18, C3, 09-17, C4, 04-10, C4, 10-18, C5, 08-17, DS3, 10-19, DS3, 10-19, DS4, 11-18, DS5, 11-19
- ▶ Mini (R55/56/57/58/59/60/61), 06-16
- ▶ Peugeot 207, 06-15, 208, 12-19, 308, 07-15, 308, 13-21, 508, 10-18, 508, 18-, 2008, 13-19, 3008, 09-16, 5008, 09-17, 5008, 17-, RCZ, 10-15, Partner Tepee, 08-18

Engine codes:

- ▶ Mini N12, N14, N16
- ▶ PSA 5FA, 5FD, 5FE, 5FF, 5FG, 5FH, 5FK, 5FM, 5FN, 5FP, 5FR, 5FS, 5FT, 5FU, 5FV, 5FW, 5FX, 5FY, 5GF, 5GG, 5GN, 5GP, 5GR, 5GT, 5GX, 5GY, 5GZ, 8FN, 8FP, 8FR, 8FS, GCR, GFR, GGR, EP3, EP3C, EP6, EP6C, EP6CB, EP6CDT, EP6CDTM, EP6CDTMD, EP6CDTR, EP6CDTX, EP6DT, EP6DTS, EP6DTX, EP6FADTX, EP6FADTXD, EP6FDT, EP6FDTM, EP6FDTMD, EP6FDTR, EP6FDTX

Used equivalent to the following OE numbers:

- ▶ Locking tool camshaft, BMW 11 9 540, PSA 0197-A3
- ▶ Locking tool camshaft, BMW 11 9 550, PSA 0197-A2
- ▶ Timing chain pre-tensioning tool, BMW 11 9 340, PSA 0197-M
- ▶ Locking tool crankshaft, BMW 11 9 590, PSA 0197-BZ



Citroën
Mini
Peugeot

Description	Article	Price EUR*
Engine timing tool set, Citroën / Mini / Peugeot	26374L	90.50

ENGINE TIMING TOOL SET, BMW

for locking the camshaft and crankshaft on 1.6 BMW N13 and N18 engines

Installed in the following vehicles:

- ▶ BMW 1er (F20/21), 11-19
- ▶ BMW 3er (F30/31/34/35), 11-19
- ▶ Mini (R55/56/57/58/59/60/61), 06-16

Engine codes: N13, N18

Used equivalent to the following OE numbers:

- ▶ Timing chain pre-tensioning tool, BMW 11 9 340
- ▶ Locking tool camshafts, BMW 11 7 440
- ▶ Locking tool crankshaft, BMW 2 299 362
- ▶ Locking tool crankshaft, BMW 11 9 590



BMW
Mini

Description	Article	Price EUR*
Engine timing tool set, BMW	26382L	90.50

ENGINE TIMING TOOL SET, MINI

Contains important tools e.g. for the following tasks on petrol engines W10, W11, N14.

- ▶ Work on intake and exhaust camshaft
- ▶ Fixing the crankshaft

Suitable for:

- ▶ Mini One, Mini Cooper, Cooper S, Cooper S JC, Cooper S JCW of model series R50, R52, R53, R55, R56, R57

Used equivalent to the following OE numbers:

- ▶ Motor support 11 8 370
- ▶ Holder camshaft 11 8 250
- ▶ Crankshaft fixing 11 9 590
- ▶ Camshaft fixing 11 9 550

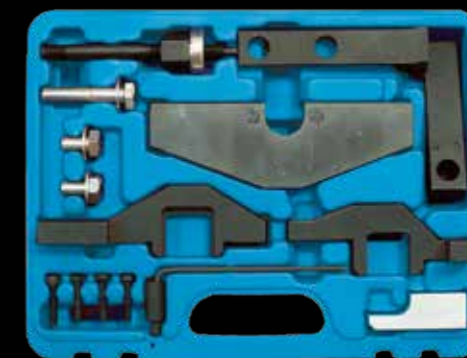

Mini

Description	Article	Price EUR*
Engine timing tool set, Mini	26106L	138.50

ENGINE TIMING TOOL SET, BMW

contains important tools e.g. for performing the following tasks on 2.0i petrol engines with engine codes N20 / N26.

- ▶ For installing and removing the camshafts
- ▶ For checking and setting the camshaft timing
- ▶ For replacing the timing chain
- ▶ For replacing the cylinder head gasket
- ▶ For setting the Vanos adjustment unit
- ▶ For pre-tensioning the chain tensioner

Suitable for BMW:

- ▶ 125i (F20) from '12, 220i (F22) from '13, 228i (F22) from '14, 320i (F30) from '12, 328i (F30) from '11, 520i (F10) from '11, 528i (F10) from '11, X1 2.0i (E84) from '11, X1 2.8i (E84) from '11, X3 2.0i (F25) from '11, X3 2.8i (F25) from '11, Z4 1.8i (E89) from '13, Z4 2.8i (E89) from '11.



BMW

Description	Article	Price EUR*
Engine timing tool set, BMW	26145L	215.00

ENGINE TIMING TOOL SET, BMW

contains important tools for working on 1.6l petrol engines with the engine code N40, N45 e.g.

- ▶ for installing and removing the camshafts
- ▶ for checking and setting the camshaft timing
- ▶ for replacing the timing chain
- ▶ for replacing the cylinder head gasket
- ▶ for setting the Vanos adjustment unit
- ▶ for pre-tensioning the chain tensioner

Suitable for:

- ▶ BMW 116i (E81 / E87) engine code: N45, model years: 2004-2010
- ▶ BMW 316i/316ti (E46) engine code: N40, model years: 2002-2005
- ▶ BMW 316i (E90) engine code: N45, model years: 2007-2009

Used equivalent to the following OE numbers:

- ▶ camshaft fixing kit BMW OE no. 11 7 250 (11 7 251 inlet camshaft, 11 7 252 exhaust camshaft, 11 7 253 screw)
- ▶ chain tensioner pre-tension BMW OE no. 11 9 340
- ▶ camshaft sensing wheels fixing kit BMW OE no. 11 7 260
- ▶ crankshaft fixing pin BMW OE no. 11 9 190



BMW

Description	Article	Price EUR*
Engine timing tool set, BMW	26210L	101.90

ENGINE TIMING TOOL SET, BMW

Contains important tools e.g. for the following tasks on 4 cylinders petrol engines N42, N46 and N46T.

- ▶ Installing and removing the camshafts and the variable camshaft unit (double variable camshaft phasing)
- ▶ Checking and setting the engine timing

Suitable for: BMW 1-series E81/E87, 3-series E46, E90, E91, X3 E83, Z4 E85, 5er E60, E61



BMW

Description	Article	Price EUR*
Engine timing tool set, BMW	26105L	237.90

ENGINE TIMING TOOL SET, BMW

for locking the camshaft and crankshaft on 1.6, 1.8 and 2.0 BMW N43 engines

Installed in the following vehicles:

- ▶ BMW 1er (E81/82/87/88) ,04-13
- ▶ BMW 3er (E90/91/92/93) ,05-13
- ▶ BMW 5er (E60/61) ,03-10

Used equivalent to the following OE numbers:

- ▶ Timing chain pre-tensioning tool, BMW 11 9 340
- ▶ Locking tool chain tensioner, BMW 11 3 340
- ▶ Adjustment tool pulse generator, BMW 11 8 710
- ▶ Locking tool camshafts, BMW 11 8 690
- ▶ Adjustment tool balance shafts, BMW 11 8 700
- ▶ Locking tool flywheel, BMW 11 5 120



BMW

Description	Article	Price EUR*
Engine timing tool set, BMW	26378L	158.50

ENGINE TIMING TOOL SET, BMW

for locking the camshaft and crankshaft on 1.6, 2.0 and 3.0 BMW diesel engines

Installed in the following vehicles:

- ▶ BMW 1er (E81/82/87/88) ,04-13, 1er (F20/21) ,11-19
- ▶ BMW 2er (F22/23/87) ,13-21
- ▶ BMW 3er (E90/91/92/93) ,05-13, 3er (F30/31/34/35) ,11-19
- ▶ BMW 4er (F32/33/36) ,13-21
- ▶ BMW 5er (E60/61) ,03-10, 5er (F10/11/18) ,10-17
- ▶ BMW 6er (F12/13/06) ,11-18
- ▶ BMW 7er (F01/02/03/04) ,08-15
- ▶ BMW X1 (E84) ,09-15
- ▶ BMW X3 (E83) ,03-10, X3 (F25) ,10-17
- ▶ BMW X4 (F26) ,14-18
- ▶ BMW X5 (E70) ,06-13, X5 (F15/85) ,13-18
- ▶ BMW X6 (E71/72) ,08-14, X6 (F16/86) ,14-19
- ▶ Mini (R55/56/57/58/59/60/61) ,06-16

Engine codes: N47, N57

Used equivalent to the following OE numbers:

- ▶ Locking tool chain tensioner, BMW 11 3 340
- ▶ Locking tool flywheel, BMW 11 5 320
- ▶ Locking tool camshaft, BMW 11 8 760
- ▶ Sprocket puller fuel pump, BMW 11 8 030
- ▶ Crankshaft turning tool, BMW 11 6 480
- ▶ Crankshaft retaining tool, BMW 11 4 320
- ▶ Locking tool flywheel, BMW 11 9 260



BMW
Mini

Description	Article	Price EUR*
Engine timing tool set, BMW	26379L	90.50

SPROCKET PULLER FUEL PUMP, BMW

for dismantling and assembling the pump shaft on BMW Common-Rail diesel engines M47, M47T2, M47TU, M57, M57TU.

- ▶ 7-Series, 94 - ,01 (E38)
- ▶ 5-Series, 95 - ,03 (E39)
- ▶ 5-Series from model year ,03 (E60) + Touring (E61)
- ▶ 3-Series, 98 - ,07 (E46)
- ▶ X5, 99 - ,06 (E53)



BMW

Description	Article	Price EUR*
Sprocket puller fuel pump, BMW	26034L	11.90

SPROCKET PULLER FUEL PUMP, BMW

for pulling off the sprocket when removing the high-pressure fuel pump on BMW engines

Suitable for the following vehicles:

- ▶ BMW 116d, 118d, 120d, 123d (E81, E82, E87, E88, F20) / 316d, 318d, 320d, 325d, 330d (E90, E91, E92, E93, F30) / 520d, 525d, 530d, 530d GT, 535d, 535d GT, M550d (E60, E61, F07, F10, F11) / 640d (F12) / 730d, 740d, 750d (F01) / X1-1.8d, 2.0d, 2.3d (E84) / X3-1.8d, 2.0d, 3.0d, 3.5d (E83, F25) / X5-3.0d, 4.0d, M5.0d (E70) / X6-3.0d, 4.0d, M5.0d (E71)

Engine codes: N47, N47S, N57, N57S

Used equivalent to the following OE numbers:

- ▶ Puller, OE number 11 8 740
- ▶ Puller sleeve, OE number 11 8 741
- ▶ Hexagon adapter, OE number 11 8 742



BMW

Description	Article	Price EUR*
Sprocket puller fuel pump, BMW	26370L	9.00

ENGINE TIMING TOOL SET, BMW

suitable for operations on BMW 2.5 l and 3.0 l, 6-cylinder petrol engines with double camshaft, installed in the following vehicles:

- ▶ Alpine B3 E90 / E91 / E92 / E93 / F30 / F31
- ▶ Alpine B4 F32 / F33
- ▶ BMW 1 Series E81 / E82 / E87 / E88 / F20 / F21
- ▶ BMW 2 Series F22 / F23 / F87
- ▶ BMW 3 Series E90 / E91 / E92 / E93 / F30 / F31 / F34 / F35 / F80
- ▶ BMW 4 Series F32 / F33 / F36 / F82 / F83
- ▶ BMW 5 Series E60 / E61 / F07 / F10 / F11 / F18
- ▶ BMW 6 Series E63 / E64 / F06 / F12 / F13
- ▶ BMW 7 Series E65 / E66 / E67 / F01 / F02 / F03 / F04
- ▶ BMW X1 series E84
- ▶ BMW X3 series E83 / F25
- ▶ BMW X4 series F26
- ▶ BMW X5 series E70 / F15 / F85
- ▶ BMW X6 series E71 / E72 / F16 / F86
- ▶ BMW Z4 series E85 / E86 / E89
- ▶ Morgan EVA GT

Engine codes: N51 / N52 / N52K / N53 / N54 / N55

Used equivalent to the following OE numbers:

- ▶ 11 0 300
- ▶ 11 4 280
- ▶ 11 4 281
- ▶ 11 4 282
- ▶ 11 4 283
- ▶ 11 4 285
- ▶ 11 4 290
- ▶ 11 8 520
- ▶ 11 9 340



BMW
Morgan

Description	Article	Price EUR*
Engine timing tool set, BMW	26339L	203.90

ENGINE TIMING TOOL SET, BMW / MINI

for a professional engine repair at 1.5 and 2.0 l BMW diesel engines B37 and B47, installed in the following vehicles:

BMW:

- ▶ 1 (F20/F21)
- ▶ 2 (F22/F23/F45/F46/F87)
- ▶ 3 (F30/F31/F34/F80)
- ▶ 4 (F32/F33/F36/F82/F83)
- ▶ 5 (F10/F11/F90/G30/G31)
- ▶ 6 (G32)
- ▶ 7 (G11/G12)
- ▶ X1 (F48)
- ▶ X2 (F39)
- ▶ X3 (F25/G01)
- ▶ X4 (F26/G02)
- ▶ X5 (F15/F85)

Mini:

- ▶ Mini (F55/F56/F57)
- ▶ Clubman (F54)
- ▶ Countryman (F60)

Used equivalent to the following OE numbers:

- ▶ 11 4 120
- ▶ 11 4 180
- ▶ 11 6 480
- ▶ 11 8 030
- ▶ 11 8 760
- ▶ 11 9 264
- ▶ 11 9 265
- ▶ 2 288 380
- ▶ 2 357 904
- ▶ 2 365 488



BMW
Mini

Description	Article	Price EUR*
Engine timing tool set, BMW / Mini	26332L	124.50

TENON WRENCH, BMW / MINI

serves as a release key for the camshaft adjusters on the BMW / Mini B38, B46 and B48 engines.

Used equivalent to OE number: 2 360 895.



BMW
Mini

Description	Article	Price EUR*
Tenon wrench, BMW / Mini	10567L	24.90

SPECIAL SOCKET, 1/2"

for operations on the central valve of the camshaft adjuster on BMW and Mini.

Suitable for the following vehicles:

BMW:

- ▶ 1 F20/F21
- ▶ 2 F22/F23/F45/F46/F87
- ▶ 3 F30/F31/F34/F80
- ▶ 4 F32/F33/F36/F82/F83
- ▶ 5 F90/G30/G31
- ▶ 6 G32
- ▶ 7 G11/G12
- ▶ X1 F48
- ▶ X2 F39
- ▶ X3 G01
- ▶ X4 G02

Mini:

- ▶ F54/F55/F56/F57/F60

Engine codes: B36A, B38A, B38B, B46A, B48A, B48B, B58B

Used equivalent to BMW OE number 2 450 487.



BMW
Mini

Description	Article	Price EUR*
Special socket, 1/2"	04466L	7.00

LOCKING TOOL FLYWHEEL, BMW / MINI

for locking the flywheel during repair work on the timing drive

Engine codes: M47TU, M54, M57T2, M57TU, N40, N42, N43, N45, N45T, N46, N46T, N51, N52, N53, N54, N62, N73, S85, W17

Used equivalent to the following OE number:

- ▶ BMW 11 9 260



BMW
Mini

Description	Article	Price EUR*
Locking tool flywheel, BMW / Mini	26380L	35.90

REMOVAL AND ASSEMBLY SET RETURN SPRING, CITROËN / MINI / PEUGEOT

Special tool for assembling and disassembling the return spring on the intermediate lever on Citroën, Mini, Peugeot vehicles with variable valve timing.

Citroën
Mini
Peugeot

Suitable for the following vehicles:

- ▶ Citroën: Berlingo, C3 II, C3 Picasso, C4 I, C4 II, C4 Picasso, C5 III, DS3, DS4, DS5
- ▶ Mini: Clubman (R55), Countryman (R60), Mini (R56 / R57 / R58 / R59), Paceman (R61)
- ▶ Peugeot: 207, 208, 2008, 308, 3008, 408, 508, 5008, RCZ, Partner Tepee

Engine Codes:

- ▶ Mini N12, N16, N18
- ▶ Citroën / Peugeot: EP3, EP3C, EP6, EP6C

Used equivalent to the following OE numbers:

- ▶ 11 9 570
- ▶ 11 9 571
- ▶ 11 9 572
- ▶ 0197-3B

2-piece



Description	Article	Price EUR*
Removal and assembly set return spring, Citroën / Mini / Peugeot	26302L	164.00

SLIDING BLOCK FIXING TOOL, BMW / MINI

Special plier for fixing and aligning the sliding blocks on the eccentric shaft of BMW / Citroën / Mini / Peugeot vehicles with variable valve timing.

BMW
Citroën
Mini
Peugeot

Suitable for the following vehicles:

- ▶ BMW: 1 (F20 / F21), 3 (F30 / F31 / F35 / F80)
- ▶ Citroën: Berlingo, C3 II, C3 Picasso, C4 I, C4 II, C4 Picasso, C5 III, DS3, DS4, DS5
- ▶ Mini: Clubman (R55), Countryman (R60), Mini (R56 / R57 / R58 / R59), Paceman (R61)
- ▶ Peugeot: 207, 208, 2008, 308, 3008, 408, 508, 5008, RCZ, Partner Tepee

Engine Codes:

- ▶ BMW N13
- ▶ Mini N12, N16, N18
- ▶ Citroën / Peugeot: EP3, EP3C, EP6, EP6C

Used equivalent to the following OE numbers:

- ▶ 11 9 573
- ▶ 0197-3C



Description	Article	Price EUR*
Sliding block fixing tool, BMW / Mini	26301L	76.50

REMOVAL AND ASSEMBLY SET RETURN SPRING, BMW

for assembly and disassembly of intermediate lever compression springs on BMW vehicles with variable valve timing.

BMW

Suitable for the following BMW vehicles:

- ▶ 1 (E81 / E82 / E87 / E88)
- ▶ 1 (F20 / F21)
- ▶ 2 (F22 / F23 / F87)
- ▶ 3 (E90 / E91 / E92 / 93)
- ▶ 3 (F30 / F31 / F34 / F80)
- ▶ 4 (F32 / F33 / F36 / F83 / F82)
- ▶ 5 (E60 / E61)
- ▶ 5 (F07 / F10 / F11)
- ▶ 6 (E63 / E64)
- ▶ 6 (F06 / F12 / F13)
- ▶ 7 (E65 / E66 / E67)
- ▶ 7 (F01 / F02 / F03 / F04)
- ▶ X1 (E84)
- ▶ X3 (E83)
- ▶ X3 (F25)
- ▶ X4 (F26)
- ▶ X5 (E70)
- ▶ X5 (F15 / F86)
- ▶ X6 (F16 / F86)
- ▶ Z4 (E85 / E86 / E89)

Engine codes: N13, N20, N26, N52, N55

Used equivalent to OE number 11 7 110.



Description	Article	Price EUR*
Removal and assembly set return spring, BMW	26195L	137.90

SLIDING BLOCK FIXING TOOL, BMW

Special tool for fixing and aligning the sliding blocks on the eccentric shaft of BMW vehicles with variable valve timing.

BMW

Suitable for the following BMW vehicles:

Engine codes: N20, N26, N52, N55

- ▶ 1 (E81 / E82 / E87 / E88)
- ▶ 1 (F20 / F21)
- ▶ 2 (F22 / F23 / F87)
- ▶ 3 (E90 / E91 / E92 / 93)
- ▶ 3 (F30 / F31 / F34 / F80)
- ▶ 4 (F32 / F33 / F36 / F83 / F82)
- ▶ 5 (E60 / E61)
- ▶ 5 (F07 / F10 / F11)
- ▶ 6 (E63 / E64)
- ▶ 6 (F06 / F12 / F13)
- ▶ 7 (E65 / E66 / E67)
- ▶ 7 (F01 / F02 / F03 / F04)
- ▶ X1 (E84)
- ▶ X3 (E83)
- ▶ X3 (F25)
- ▶ X4 (F26)
- ▶ X5 (E70)
- ▶ X5 (F15 / F86)
- ▶ X6 (F16 / F86)
- ▶ Z4 (E85 / E86 / E89)

Used equivalent to OE number 11 4 450.



Description	Article	Price EUR*
Sliding block fixing tool, BMW	26304L	67.90

COUNTERHOLDER CRANKSHAFT, BMW / MINI / PEUGEOT

for loosening and tightening the crankshaft central screw.

Suitable for:

- ▶ BMW / Mini: N12, N14, N18, N40, N42, N43, N45, N46, N51, N52, N53, N63
- ▶ Peugeot: EP3, EP6, EP6DT, EP6DTS

Used equivalent to the following OE-number:

- ▶ BMW OE-No. 11 9 280



BMW
Mini
Peugeot

Description	Article	Price EUR*
Counterholder crankshaft, BMW / Mini / Peugeot	10589L	33.90

LOCKING TOOL FLYWHEEL, BMW / MINI

For locking the flywheel when loosening and tightening the central screw on the vibration damper on diesel and petrol engines with engine codes:

- ▶ M47T2 / M47TU / M57T2 / M57TU / M67 / N43 / N45 / N45T / N46 / N46T / N47 / N47S / N51 / N52 / N53 / N54 / W17

For the following work, e.g.

- ▶ Exchanging the vibration damper
- ▶ Replacing the crank shaft radial seal ring (on the front)

Suitable for:

- ▶ 116i, 118i, 120i, 128i, 130i, 135i, 135is, 118d, 120d, 123d (E81, E82, E87, E88) / 316i, 318i, 318ti, 320i, 320Si, 323i, 325i, 325xi, 328i, 328xi, 330i, 330xi, 335i, 335xi, 318d, 320d, 320td, 325d, 330d, 330xd, 335d (E46, E90, E91, E92, E93) / 520i, 523i, 525i, 525xi, 530i, 530xi, 535i, 535xi, 520d, 525d, 525xd, 530d, 530xd, 535d, (E60, E61) / 630i, 635d (E63, E64) / 730i, 730d, 740d, (E38, E65, E66) / X3-2.0i, X3-2.0d, X3-3.0d, X5-3.0d, X6-3.5d, X6-3.0d, X6-3.5d (E53, E70, E83) / Z4-2.0i, Z4-2.5i, Z4-3.0i (E85, E86) / Mini One, (R50)

Used equivalent to the following OE numbers:

- ▶ Counter support (complete) 11 8 180
- ▶ Connecting holder 11 8 182
- ▶ Base plate 11 8 183
- ▶ Adaptor (for E65/M67) 11 8 184
- ▶ Adaptor with an adjusting sleeve (for E46/M47TU) 11 8 185



BMW
Mini

Description	Article	Price EUR*
Locking tool flywheel, BMW / Mini	10588L	84.90

BALANCE SHAFT FIXATION, BMW N40-N46

Fixing gauge for adjusting the balancer shafts in the oil pump unit. Opening: 6 mm

Suitable for:

- ▶ BMW models with engine code N40, N42, N45, N46

Used equivalent to the following OE-number:

- ▶ BMW OE-No. 11 9 330



BMW

Description	Article	Price EUR*
Balance shaft fixation, BMW N40-N46	26143L	9.40

BALANCE SHAFT FIXATION, BMW N40-N46

Fixing gauge for adjusting the balancer shafts in the oil pump unit (new version).

Suitable for BMW models with engine codes: N40, N42, N45, N46.

Used equivalent to the following OE-number:

- ▶ BMW OE-Nr. 11 5 140



BMW

Description	Article	Price EUR*
Balance shaft fixation, BMW N40-N46	26144L	16.90

TIMING BELT INSPECTION TOOL, CITROËN / OPEL / PEUGEOT / TOYOTA

Some engines use timing belts that run in oil. Ageing or using the wrong engine oils can change the structure of the timing belt, increasing its width. With this inspection tool, the width of the timing belt can be checked quickly and easily. This check must be carried out during all maintenance work (every 12 months or 20,000 km). To do this, remove the oil filler cap and measure the width of the timing belt.

Suitable for:

- ▶ Citroën Berlingo, C1 II, C3 II/III, C4 II, C5 X, C-Elysee, DS3 and DS4
- ▶ Opel Astra L, Crossland X, Grandland X, Mokka
- ▶ Peugeot 108, 208 I/II, 2008 I/II, 308 II/III, 3008, 508 II, 5008, Partner Tepee, Rifter
- ▶ Toyota Aygo II

Engine codes: 1PP, B12XE, B12XHL, B12XHT, D12XE, D12XHL, D12XHT, F12XE, F12XHL, F12XHT, EBO, EB2, EB2ADT, EB2ADTD, EB2ADTS, EB2D, EB2DT, EB2DTM, EB2DTS, EB2DTSd, EB2F, EB2FA, EB2FB, EB2FD, EB2M, HMP, HMR, HMT, HMU, HMY, HMZ, HNK, HNP, HNS, HNV, HNX, HNY, HNZ, ZMZ

Used equivalent to the following OE numbers:

- ▶ Opel EN-52809
- ▶ PSA 0109-6
- ▶ Toyota 16431-90080



Citroën
Opel
Peugeot
Toyota
Vauxhall

Description	Article	Price EUR*
Timing belt inspection tool, Citroën / Opel / Peugeot / Toyota	26324L	7.30

ENGINE TIMING TOOL SET, OPEL

Contains important tools e.g. for the following work:

- ▶ Locking the flywheel
- ▶ Locking the crankshaft
- ▶ Locking the camshaft
- ▶ Locking the injection pump shaft
- ▶ Pulling off the crankshaft belt pulley
- ▶ Tensioning the timing belt

Used equivalent to the following OE numbers:

- ▶ KM-852
- ▶ KM-853
- ▶ KM-911
- ▶ KM-927
- ▶ KM-929
- ▶ KM-933
- ▶ KM-952
- ▶ KM-953
- ▶ KM-954
- ▶ KM-955
- ▶ KM-6077
- ▶ KM-6130
- ▶ KM-6148
- ▶ EN-46781
- ▶ EN-46785
- ▶ EN-46788/1 860 905 000



Opel
Saab

Description	Article	Price EUR*
Engine timing tool set, Opel	26053L	260.50

ENGINE TIMING TOOL SET, OPEL / VAUXHALL

contains the most important tools for repair work on 1.0, 1.2 and 1.4 l. Opel engines with double camshaft

Suitable for the following vehicles:

- ▶ Nissan Pixo ,09-'13
- ▶ Opel Agila A ,00-'07, Astra G ,98-'09, Astra H ,04-'09, Combo C ,01-'11, Corsa B ,93-'00, Corsa C ,00-'06, Corsa D ,06-'14, Meriva A ,03-'10, Tigra B ,04-'10
- ▶ Suzuki Alto ,09-'15, Alto ,14-, Celerio ,14-, Splash ,08-'14, Wagon R ,03-'08

Engine codes:

- ▶ Nissan K10B
- ▶ Opel X10XE, X12XE, Z10XE, Z10XEP, Z12XE, Z12XEP, Z14XEL, Z14XEP
- ▶ Suzuki K10B

Used equivalent to the following OE numbers:

- ▶ Adjusting tool camshafts, Opel KM-953A
- ▶ Locking pin crankshaft, Opel KM-952
- ▶ Setting gauge pulse encoder disc, Opel KM-954
- ▶ Locking pin chain tensioner, ø 2.5 mm, Opel EN-955-1
- ▶ Locking pin chain tensioner, ø 4.0 mm, Opel EN-955-2



Nissan
Opel
Suzuki
Vauxhall

Description	Article	Price EUR*
Engine timing tool set, Opel / Vauxhall	26350L	33.90

ENGINE TIMING TOOL SET, OPEL

for locking the camshafts and crankshaft on 3 cylinder 1.0 turbo SIDI petrol engines.

Installed in the following vehicles:

- ▶ Opel Adam ,12-'19, Astra K ,15-'22, Corsa E ,14-'19

Engine codes: B10XFL, B10XFT, B10XHL, D10XFL, D10XFT, F10XFL, F10XFT

Used equivalent to the following OE numbers:

- ▶ Balance shaft retaining tool, Opel EN-51298
- ▶ Locking tool camshafts, Opel EN-51367



Opel
Vauxhall

Description	Article	Price EUR*
Engine timing tool set, Opel	26315L	56.50

ENGINE TIMING TOOL SET, OPEL / VAUXHALL

contains the most important tools for repair work on 1.0, 1.2 and 1.4 l. Opel engines with double camshaft

Suitable for the following vehicles:

- ▶ Chevrolet Aveo ,11-, Cruze ,10-, Orlando ,12-, Trax ,12-
- ▶ Opel Adam ,12-'19, Ampera ,11-'15, Astra J ,09-'15, Cascada ,13-'18, Corsa D ,06-'14, Corsa E ,14-, Insignia A ,11-'17, Meriva B ,10-'17, Mokka ,12-, Zafira C ,11-

Engine codes:

- ▶ Chevrolet: LDC, LDD, LUJ, LWD
- ▶ Opel: A10XEP, A12XEL, A12XER, A14NEL, A14NET, A14XEL, A14XER, A14XFL, B12XEL, B14NEH, B14NEJ, B14NEL, B14NET, B14XEJ, B14XEL, B14XER, D12XEL, D14NEH, D14NEJ, D14NEL, D14NET, D14XEL, D14XER

Used equivalent to the following OE numbers:

- ▶ Locking tool camshaft position sensor, Opel EN-49977-100
- ▶ Locking tool camshaft adjuster, Opel EN-49977-200
- ▶ Locking tool pulser wheel, Opel EN-49978
- ▶ Locking pin crankshaft, Opel KM-952
- ▶ Adjusting tool camshafts, Opel KM-953A
- ▶ Locking pin chain tensioner, ø 2.5 mm, Opel EN-955-1
- ▶ Locking pin chain tensioner, ø 4.0 mm, Opel EN-955-2



Chevrolet
Opel
Vauxhall

Description	Article	Price EUR*
Engine timing tool set, Opel / Vauxhall	26362L	102.90

ENGINE TIMING TOOL SET, CITROËN / OPEL / PEUGEOT / TOYOTA

for locking the camshaft and crankshaft on 1.0 and 1.2 litre petrol engines, also suitable for PureTech engines

Installed in the following vehicles:

- ▶ Citroën Berlingo II/III, C-Elysee, C1 II, C3 II/III, C4 II, C4 Cactus, DS3, DS4
- ▶ Fiat Doblo
- ▶ Jeep Avenger
- ▶ Opel Astra L, Combo E, Corsa F, Crossland X, Grandland, Mokka B
- ▶ Peugeot 108, 208 I/II, 301, 308 II, 408 II, 508 II, 2008 I/II, 3008 I/II, 5008 I/II, Partner Tepee, Rifter
- ▶ Toyota Aygo, Proace

Engine codes:

- ▶ Citroën: HMP, HMR, HMT, HMU, HMY, HMZ, HNP, HNS, HNV, HNX, HNY, HNZ, ZMZ
- ▶ Opel: B12XE, B12XHL, B12XHT, D12XE, D12XHL, D12XHT, F12XE, F12XHL, F12XHT
- ▶ Peugeot: EBO, EB2, EB2ADT, EB2ADTS, EB2D, EB2DT, EB2DTM, EB2DTS, EB2DTSO, EB2F, EB2FA, EB2FB, EB2FD, EB2M
- ▶ Toyota: 1PP, EB2ADT, EB2ADTS

Used equivalent to the following OE numbers:

- ▶ Camshaft locking tool, Opel EN-52127-1, PSA 0109-2A
- ▶ Camshaft locking tool, PSA 0109-2C
- ▶ Camshaft locking tool, PSA 0109-2D
- ▶ Camshaft locking tool, PSA 0109-2E
- ▶ Flywheel locking tool, Opel EN-52127-2, PSA 0109-2B
- ▶ Flywheel locking tool, Opel EN-52588, PSA 0197-N
- ▶ Locking pin for V-ribbed belt tensioning element, Opel EN-52141



NEW PRODUCT

Citroën
Opel
Peugeot
Toyota
Vauxhall

Description	Article	Price EUR*
Engine timing tool set, Citroën / Opel / Peugeot / Toyota	26346L	135.90

ENGINE TIMING TOOL SET, OPEL

for locking the camshaft and crankshaft on 1.0 ltr., 1.4 with and without turbo and 1.5 turbo engines

Installed in the following vehicles:

- ▶ Opel Astra K, 15-22, Insignia B, 17-, Karl, 15-19 und Mokka A, 12-20

Engine codes: B10XE, B10XL, B14XE, B14XFL, B14XFT, B14XNT, B15SFL, B15SFT, D10XE, D14XFL, D14XFT, D15SFL, D15SFT

Used equivalent to the following OE numbers:

- ▶ Crankshaft pulley puller, Opel EN-44226
- ▶ Locking pin chain tensioner, Opel EN-49073
- ▶ Adjusting ruler for camshafts, vehicles with turbocharger, Opel EN-51367
- ▶ Adjusting ruler for camshafts, vehicle without turbocharger, Opel EN-51632



Opel
Vauxhall

Description	Article	Price EUR*
Engine timing tool set, Opel	26316L	153.00

ENGINE TIMING TOOL SET, OPEL

for locking the camshaft and crankshaft on 1.6 SIDI engines

Installed in the following vehicles:

- ▶ Opel Astra J, 09-15, Cascada, 13-19, Insignia A, 08-17, Insignia B, 17-, Zafira C, 11-19

Engine codes: A16SHT, A16XHT, B16SHL, B16SHT, D16SHJ, D16SHL, D16SHT

Used equivalent to the following OE numbers:

- ▶ Locking tool camshafts, Opel EN-51148
- ▶ Pulley retaining tool, Opel EN-51147
- ▶ Locking pin chain tensioner, Opel EN-50513



Opel
Vauxhall

Description	Article	Price EUR*
Engine timing tool set, Opel	26317L	130.00

ENGINE TIMING TOOL SET, ALFA / FIAT / OPEL / SAAB / VAUXHALL

contains the most important tools for repair work on 1.4, 1.6 and 1.8 l Opel and Fiat petrol engines.

Suitable for the following vehicles:

- ▶ Alfa Romeo 159, 05-11
- ▶ Chevrolet Aveo I, 08-15, Aveo II, 11-20, Cruze, 09-16, Orlando, 10-18, Trax, 13-
- ▶ Fiat Croma, 05-10
- ▶ Opel Astra G, 02-06, Astra H, 04-12, Astra J, 09-15, Corsa D, 0-14, Corsa E, 15-19, Insignia A, 08-17, Meriva A, 06-10, Mokka A, 12-19, Signum, 05-08, Vectra C, 05-08, Zafira A, 03-05, Zafira B, 05-15, Zafira C, 11-19
- ▶ Saab 9-5, 10-12

Engine codes:

- ▶ Alfa Romeo 939A4.000
- ▶ Chevrolet 2H0, LDE, LDT
- ▶ Fiat 939A4.000
- ▶ Opel A16LEL, A16LER, A16LES, A16LET, A16XER, A16XNT, A18XEL, A18XER, B16LER, B16LES, B16XER, B16XNT, B18XER, D16XER, Z16LEL, Z16LER, Z16LET, Z16XE1, Z16XEP, Z16XER, Z16XNT, Z18XER
- ▶ Saab A16LET

Used equivalent to the following OE numbers:

- ▶ Adjusting tool camshafts, Opel KM-6628-A
- ▶ Locking tool camshafts, Opel EN-6340
- ▶ Locking pin tensioner, Opel EN-6333
- ▶ Locking tool flywheel, Opel EN-6625
- ▶ Locking pin tensioner V-ribbed belt, Opel KM-6130
- ▶ Locking tool flywheel, Opel KM-911



Alfa Romeo
Chevrolet
Fiat
Opel
Saab
Vauxhall

Description	Article	Price EUR*
Engine timing tool set, Alfa / Fiat / Opel / Saab / Vauxhall	26363L	28.50

ENGINE TIMING TOOL SET, ALFA ROMEO / FIAT / FORD / OPEL

for checking or adjusting the timing and change the timing chain on 1.3 JTD / CDTi / TDCi diesel engines.

- ▶ Suzuki: D13A, Z13DT, Z13DTJ

Used equivalent to the following OE numbers:

- ▶ Crankshaft lock can be used as OE no. 1.870.900.300, 303-1468, 09912-38300, 0104-C
- ▶ Cam counter holder can be used as OE no. 1.871.008.600, 303-1475, 09917-68221, 0104-B
- ▶ Flywheel lock 09912-46310, EN-46785
- ▶ Flywheel lock 09916-98610, EN-955-A
- ▶ Crankshaft counterweight 1.871.000.200
- ▶ Tensioner roller lock KM-6130, 0198-J
- ▶ Spreading lever timing chain tension 1.870.900.400, 303-1469
- ▶ Camshaft lock 1.871.000.900, 303-1472, 09917-68610, EN-46781, 0104-A

Suitable for:

- ▶ Alfa Romeo MiTo 2008-
- ▶ Chevrolet Aveo 2011, Cobalt 2013, Enjoy 2013, Montana 2011, Sail 2011, Sonic 2011, Spin 2012
- ▶ Citroën Nemo 2008-
- ▶ Fiat 500 2007-, Doblo 2000-2010, Doblo 2010-, Fiorino 2007-, Idea 2004-, Linea 2006-, Palio 2003-, Panda 2003-2013, Panda 2012-, Punto 1999-2012, Grande Punto 2005-, Qubo 2008-, Strada 2006-
- ▶ Ford Ka 2008-2015
- ▶ Lancia Musa 2004-2012, Ypsilon 2003-2011, Ypsilon 2011-
- ▶ Opel Agila A 2000-2007, Agila B 2008-2014, Astra H 2004-2014, Astra J 2009-2015, Combo 2004-2011, Corsa C 2000-2009, Corsa D 2006-2014, Meriva A 2003-2010, Meriva B 2010-2017, Tigra B 2004-2010
- ▶ Peugeot Bipper 2008-
- ▶ Subaru Justy III 2003-2007
- ▶ Suzuki Splash 2008-, Swift III 2005-2010, Swift IV 2010-

Engine codes:

- ▶ Alfa Romeo / Fiat / Lancia: 169A1,000, 169A5,000, 188A8,000, 188A9,000, 199A2,000, 199A3,000, 199A9,000, 199B1,000, 199B2,000, 223A9,000, 263A2,000
- ▶ Ford: 169A1,000, FD4, BAAA, BBAB, BBCB
- ▶ Opel / Vauxhall: L4i, LDP, LDV, LN9, LSF, A13DT, A13DTC, A13DTE, A13DTR, D13A, Y13DT, Z13DT, Z13DTE, Z13DTH, Z13DTJ, Z13DTR
- ▶ PSA: FHZ, F13DTE5



Alfa Romeo
Chevrolet
Citroën
Fiat
Ford
Lancia
Opel
Peugeot
Subaru
Suzuki

Description	Article	Price EUR*
Engine timing tool set, Alfa Romeo / Fiat / Ford / Opel	26313L	117.50

ENGINE TIMING TOOL SET, CHEVROLET/OPEL/VAUXHALL

Contains the most important tools for repair work on 1.6 CDTi ecoFLEX diesel engines.

Suitable for the following vehicles:

- ▶ Chevrolet Trax, 14-15
- ▶ Opel/Vauxhall Astra J '09-18, Astra K '15-21, Insignia A '08-17, Insignia B '17-, Meriva B '10-17, Mokka A '12-19, Zafira C '11-19

Engine codes:

- ▶ Chevrolet LVL
- ▶ Opel/Vauxhall A16DTH, B16DTC, B16DTE, B16DTH, B16DTJ, B16DTL, B16DTN, B16DTR, B16DTU, D16DTE, D16DTH, D16DTI, D16DTJ, D16DTN, D16DTR

Used equivalent to the following OE numbers:

- ▶ Locking pin tensioning pulley, OE number EN-50513
- ▶ Locking tool crankshaft, OE number EN-51140
- ▶ Locking tool camshaft, OE number EN-51143
- ▶ Locking tool camshaft sprocket, OE number EN-51188
- ▶ Locking pin V-ribbed belt, OE number EN-6349 / EN-6130



**NEW
PRODUCT**

Chevrolet
Opel
Vauxhall

Description	Article	Price EUR*
Engine timing tool set, Chevrolet/Opel/Vauxhall	26344L	62.50

ENGINE TIMING TOOL SET, CADILLAC / OPEL / SAAB

for repairs on the timing chain with 2.0 l petrol engines with turbo, installed in the following vehicles:

- ▶ Cadillac: BLS Wagon
- ▶ Opel: Signum, Vectra C
- ▶ Saab: 9-3 (YS3F)

Engine codes: B207E, B207L, Z20NET (L8Q)

Used equivalent to the following OE numbers:

- ▶ KM-J-38122-A
- ▶ KM-6362
- ▶ KM-6077
- ▶ EN-48366
- ▶ 08 396 046
- ▶ 08 396 210
- ▶ 08 396 392



Cadillac
Opel
Saab
Vauxhall

Description	Article	Price EUR*
Engine timing tool set, Cadillac / Opel / Saab	26199L	56.50

ENGINE TIMING TOOL SET, OPEL / VAUXHALL

for professional engine servicing on 2.0 l CDTi engines from year 2014, used in the following vehicles:

- ▶ Antara
- ▶ Cascada
- ▶ Insignia A
- ▶ Insignia B
- ▶ Zafira C

Engine codes: B20DTH, B20DTR, D20DTH, D20DTR

Used equivalent to the following OE numbers:

- ▶ EN-955-2
- ▶ EN-51411
- ▶ EN-51412
- ▶ EN-51413
- ▶ EN-51414



Opel
Vauxhall

Description	Article	Price EUR*
Engine timing tool set, Opel / Vauxhall	26334L	124.50

ENGINE TIMING TOOL SET, CHEVROLET / OPEL

for 2.0 l CDI / VCDI Common Rail diesel engines. For locking the crankshaft and camshaft while adjusting the timing e.g. for timing belt replacement or engine repairs.

Suitable for:

- ▶ Opel (Vauxhall) Antara, Insignia
- ▶ Chevrolet Captiva, Cruze, Epica, Lacetti, Nubira

With engine code Z20DM / Z20DMH (LLW) / Z20S / Z20S1 / RA420

Used equivalent to the following OE numbers:

- ▶ Crankshaft fixation EN-48246
- ▶ Camshaft fixation EN-48245



Chevrolet
Opel
Vauxhall

Description	Article	Price EUR*
Engine timing tool set, Chevrolet / Opel	26130L	37.50

ENGINE TIMING TOOL SET, OPEL / VAUXHALL

for professional engine servicing on 2.0 I CDTi engines from year 2014, used in the following vehicles:

- ▶ Antara
- ▶ Cascada
- ▶ Insignia A
- ▶ Insignia B
- ▶ Zafira C

Engine codes: B20DTH, B20DTR, D20DTH, D20DTR

Used equivalent to the following OE numbers:

- ▶ EN-955-2
- ▶ EN-51411
- ▶ EN-51412
- ▶ EN-51413
- ▶ EN-51414



Opel
Vauxhall

Description	Article	Price EUR*
Engine timing tool set, Opel / Vauxhall	26334L	124.50

ENGINE ADJUSTMENT TOOL SET, CHEVROLET/OPEL/SAAB

for operations on the timing chain at 2.0 and 2.4 l turbocharged petrol engines, installed in Opel, Chevrolet and Saab vehicles.

Installed in the following vehicles:

- ▶ Chevrolet Captiva (C100 / C140)
- ▶ Opel Antara, Astra J, Insignia A, Insignia B
- ▶ Saab 9-3 (YS3F), 9-5 (YS3G)

Motor codes: A20NET (LHU), A20NFT (LHU), A20NHT (LDK / LTG), A24XE (LE5), B20NFT (LHU / LTG)

Used equivalent to the following OE numbers:

- ▶ EN-48953
- ▶ EN-49212
- ▶ EN-48585
- ▶ EN-43653
- ▶ EN-45027

12-piece



Cadillac
Opel
Saab
Vauxhall

Description	Article	Price EUR*
Engine adjustment tool set, Chevrolet/Opel/Saab	26338L	135.90

ENGINE TIMING TOOL SET, OPEL / VAUXHALL

for adjusting the timing chain in the cylinder head. This is an extension set to 26334L.

Suitable for:

- ▶ Antara
- ▶ Cascada
- ▶ Insignia A
- ▶ Insignia B
- ▶ Zafira C

Engine code: B20DTH

Used equivalent to OE numbers:

- ▶ EN-51415
- ▶ EN-51418



Opel
Vauxhall

Description	Article	Price EUR*
Engine timing tool set, Opel / Vauxhall	26335L	84.90

LOCKING TOOL CAMSHAFTS

for professional locking of camshafts in TDC position during timing and engine repairs

Used equivalent to the following OE number:

- ▶ Alfa Romeo 2.000.012.100
- ▶ Opel EN-6340
- ▶ Opel KM-6340



Alfa Romeo
Opel
Vauxhall

Description	Article	Price EUR*
Locking tool camshafts	26363L-2	3.40

LOCKING TOOL, OPEL ECOTEC 1,4 AND 1,6 L

for locking the camshafts for Opel Tigra B, Sintra, Vectra, Calibra and Omega engines with 1.4l / 1.6l / 1.8l with engine code X14XE, X16SEJ, X16XEL, X18XE1, Y16XE, Z14XE, Z16XE, Z16YNG, Z18XE, Z18XEL.

Used equivalent to OE number KM-852.

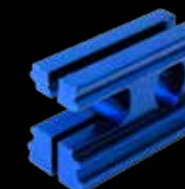

Opel
Vauxhall

Description	Article	Price EUR*
Locking tool, Opel Ecotec 1,4 and 1,6 l	26096L	11.60

LOCKING TOOL, OPEL ECOTEC 1,8 AND 2,0 L

for locking the camshafts for Astra, Omega B, Vectra B and Calibra engines.

▶ Engine code: C20SEL, X18XE, X20XEV, X22SE, X22XE, Y22SE, Y22XE, Z20LEH, Z20LEL, Z20LER, Z20LET, Z22XE

Used equivalent to the following OE no.:

- ▶ Opel KM-853



Opel
Vauxhall

Description	Article	Price EUR*
Locking tool, Opel Ecotec 1,8 and 2,0 l	26095L	8.00

LOCKING TOOL SAAB / OPEL LEFT

for locking the camshafts for Opel Sintra, Vectra, Calibra as well as Saab 900 and 9000

- ▶ Opel engines with 2.5l and 3.0l
- ▶ Saab engines with 2.5l and 3.0l

For left-hand camshaft (green tool)

Motorcode: C25XE, X25XE, X25XEI, X30XE, Y26SE, Y32SE, Z32SE, B308E, B308I



Opel
Saab
Vauxhall

Description	Article	Price EUR*
Locking tool Saab / Opel left	26097L	16.90

LOCKING TOOL SAAB / OPEL RIGHT

for locking the camshafts for Opel Sintra, Vectra, Calibra as well as Saab 900 and 9000

- ▶ Opel engines with 2.5l and 3.0l
- ▶ Saab engines with 2.5l and 3.0l

For right-hand camshaft (red tool)

Motorcode: C25XE, X25XE, X25XEI, X30XE, Y26SE, Y32SE, Z32SE, B308E, B308I



Opel
Saab
Vauxhall

Description	Article	Price EUR*
Locking tool Saab / Opel right	26098L	16.90

COUNTERHOLDER CAMSHAFT, FIAT / FORD / OPEL / PSA / SUZUKI

for holding the camshaft when loosening and tightening the camshaft gear screw connection.
For the use on popular 1.3 JTD diesel engines.

Suitable for:

- Alfa Romeo: Mito
- Citroën: Nemo
- Peugeot: Bipper
- Fiat: 500 / 500 C, Doblo / Doblo Cargo, Fiorino, Grande Punto, Idea, Linea, Panda / Panda Classic, Punto / Punto Classic, Punto Evo, Qubo
- Ford: Ka
- Lancia: Musa, Ypsilon
- Suzuki: Ignis, Splash, Swift, Wagon R+
- Vauxhall / Opel: Agila / Agila B, Astra G / Astra H, Combo C / Combo D, Corsa C / Corsa D, Meriva A / Meriva B, Tigra B, Zafira B

Motorcodes:

- Alfa Romeo: 199A3.000, 199B4.000
- Chrysler: 199B1.000
- Fiat: 169A1.000, 169A5.000, 188A8.000, 188A9.000, 199A2.000, 199A3.000, 199A9.000, 199B2.000, 199B4.000, 199B8.000, 223A9.000, 225A2.000, 263A2.000, 312A8.000, 330A1.000
- Ford: 169A1.000 (FD4)/BAAA
- Lancia: 188A9.000, 199A2.000, 199A3.000, 199A9.000, 199B1.000, 843A2.000
- Opel/Vauxhall: A13DTC, A13DTE, A13DTR, D13A, LN9 (263A2.000), LN9/A13DTC, LSF/A13DTC, LSF/A13DTE, Y13DT, Z13DT, Z13DTE, Z13DTH, Z13DTI, Z13DTJ, Z13DTR

Used equivalent to the following OE-number:

- Ford: 303-1475
- Fiat: 1.871.008.600
- PSA: 0104-B



- Alfa Romeo
- Chrysler
- Citroën
- Fiat
- Ford
- Lancia
- Opel
- Peugeot
- Suzuki
- Vauxhall

Description	Article	Price EUR*
Counterholder camshaft, Fiat / Ford / Opel / PSA / Suzuki	10592L	14.70

COUNTERHOLDER CRANKSHAFT, OPEL

suitable for Opel Adam, Astra J, Cascada, Corsa D, Insignia, Meriva B, Mokka, Zafira C with 1.0 / 1.2 / 1.4 l ecoFlex engines.

For holding the crankshaft pulley and for releasing the central fixing screw. With the handle included, the counterholder can be extended by 65 cm, thus offering the possibility of releasing fixed screwed connections. An additional 1/2' drive on the anvil alternatively allows use with a sliding handle.

Engine codes: A10XEP, A12XEL (LWD), A12XER (LDC), A14NEL (LUH), A14NET (LUJ), A14XEL (LDD), A14XER (LDD)

Used equivalent to OE numbers:

- Counterholder basic tool (equivalent to OE EN-49979)
- Extension for counterholder (equivalent to OE EN-956-1)
- Adapter, 2-piece (equivalent to OE EN49979-100)



- Opel
- Vauxhall

Description	Article	Price EUR*
Counterholder crankshaft, Opel	10566L	118.50

ENGINE TIMING TOOL SET, FORD/VOLVO

Very comprehensive universal set for vehicles with Ford petrol and diesel engines. Includes tools for locking the flywheel, crankshaft and camshaft and for adjusting the timing belt tension.

Installed in the following vehicles:

- Ford B-Max, C-Max, Ecosport, Escort, Fiesta, Courier, Focus, Fusion, Galaxy, Ka, Kuga, Mondeo, Orion, Sierra, S-Max, Tourneo, Transit
- Mazda 2, 3, 6, CX-7, MPV

Suitable for 1.25, 1.4, 1.5 EcoBlue, 1.6, 1.8, 2.3, 2.5 D/TD/TDCi

Engine codes:

- Ford: 4AB, 4BA, 4BB, 4BC, 4CA, 4CB, 4CC, 4DA, 4EA, 4EB, 4EC, 4ED, 4FA, 4FB, 4FC, 4FD, 4GA, 4GB, 4GC, 4GD, 4GE, 4GF, 4HA, 4HB, 4HC, 4HD, AEDA, BEGA, BHDA, BHDB, BHPA, C9DA, C9DB, C9DC, CFBA, F6JA, F6JB, F6JC, F6JD, F9DA, F9DB, FFBA, FFDA, FFWA, FXJA, FXJB, FXJC, G8DA, G8DB, G8DC, G8DD, G8DE, G8DF, GPDA, GPDB, GPDC, HCPA, HCPB, HCPC, HCPD, HKDA, HHDA, HHDB, HHJA, HHJB, HHJC, HHJD, HHJE, HHJF, KHBA, KKDA, KKDB, KVJA, LTA, LTB, LTC, MZJA, M7JB, MTDA, NGCA, NGDA, NGDB, P7PA, P7PB, P9PA, P9PB, P9PC, P9PD, QYBA, QYWA, R2PA, R3PA, RFA, RFB, RFD, RFK, RFL, RFM, RFN, RFS, RTA, RTB, RTC, RTD, RTE, RTF, RTG, RTH, RTJ, RTK, RTN, RTP, RTQ, RVA, RWPA, RWPB, RWPC, RWPD, RWPE, RWPF, SNJA, SNJB, SNJC, SNJD, STJA, STJB, STJC, STJD, T1BA, T1BB, T1BC, T1DA, T1DB, T1GA, T1WA, T1WB, T3CA, T3CB, T3CC, T3DA, T3DB, T3JA, T3JB, TZGA, TZGB, TZJA, TZJB, U3CA, UBGA, UBJA, UGCA, UGCB, UGCC, UGJC, UGJE, UGJG, UGJM, XUCA, XUCC, XUCD, XUCE, XUCF, XUCG, XUGA, XUJA, XUJB, XUJC, XUJD, XUJE, XUJF, XUJG, XUJH, XUJK, XUJL, XUJM, XUJN, XVCA, XVCB, XVCC, XVCD, XVGA, XVGB, XVGC, XVJA, XVJB, XVJC, XVJD, XWCA, XWCB, XWDA, XWDB, XWDC, XWDD, XWDE, XWGA, XWGB, XWGC, XWJA, XWJB, XWJC, XWMB, XWMC, XXCA, XXCB, XXCC, XXDA, XXDB, XXDC, XXDD, XXGA, Y9DA, Z2DA, Z2GA, Z2JA, ZTDA, ZTDB, ZTGA, ZTJA, ZTJB, ZTJC
- Mazda: F6JA, F6JB, FXJA, L3M6, L3-VDT, L3YH



- Ford
- Mazda

Description	Article	Price EUR*
Engine timing tool set, Ford/Volvo	26389L	107.50

ENGINE TIMING TOOL SET, FORD

Suitable for 1.0 l EcoBoost 3-cylinder petrol engines from 2012 in the following vehicles:

- Ford: B-Max, C-Max, Fiesta, Ecosport, Focus, Grand C-Max, Transit Courier, Transit Connect, Tourneo Connect

Engine codes:

- M1CA, M1CB, M1DA, M1DC, M1DD, M1DH, M1JA, M1JC, M1JE, M1JH, M1JJ, M1JL, M1JM, M2DA, M2DB, M2DC, M2GA, M2GB, P4JA, P4JB, P4JC, P4JD, QOJA, QOJB, QOJC, QOJD, SFCA, SFCB, SFCC, SFCD, SFDA, SFDB, SFJA, SFJB, SFJC, SFJD, SFJE, SFJF, SFJH, SFJJ, SFJK, SFJL, SFJN, SFJP, XMJA, XMJB, YYJA, YYJB, YYJC, YYJD, YYJE

Used equivalent to the following OE numbers:

- Fixing pin 303-732
- Tensioner fixing pin 303-1054
- Flywheel fixing tool 303-1602
- Seal ring installation tool 303-1603
- Locking tool 303-1604
- Camshaft fixing tool 303-1605
- Locking tool 303-1606
- Seal ring installation tool 303-1636
- Fixing pin T10060A



- Ford

Description	Article	Price EUR*
Engine timing tool set, Ford	26230L	169.90

ENGINE TIMING TOOL SET, FORD

for locking the camshaft and crankshaft on 1.0 EcoBoost engines.

Installed in the following vehicles:

- ▶ Ford C-Max II, 10-19, Fiesta VII, 17-, Focus IV, 18-, Puma, 19-, Transit Connect, 13-22

Engine codes: B3DA, B3GA, B3GB, B7DA, B7JA, B7JB, B7JC, B7JE, B7JG, BZJA, M0DC, MOJA

Used equivalent to the following OE numbers:

- ▶ Locking tool camshafts, Ford 303-1661/1 und /2
- ▶ Socket spanner camshaft adjuster, Ford 303-1661/3
- ▶ Locking tool camshafts, Ford 303-1604
- ▶ Crankshaft locking pin, Ford 303-732
- ▶ Locking tool flywheel, Ford 303-1643



Ford

Description	Article	Price EUR*
Engine timing tool set, Ford	26320L	260.50

ENGINE TIMING TOOL SET, FORD

for locking the camshaft and crankshaft on 1.25, 1.4, 1.6, 1.8, 2.0 and 2.3 Ford engines.

Installed in the following vehicles:

- ▶ Ford B-Max, 12-17, Cougar, 98-02, C-Max I, 03-10, C-Max II, 10-19, Fiesta IV, 95-01, Fiesta V, 01-08, Fiesta VI, 08-17, Courier, 96-02, Focus I, 98-04, Focus II, 04-10, Fusion, 02-12, Galaxy II, 06-14, Mondeo I, 93-96, Mondeo II, 96-00, Mondeo III, 00-07, Mondeo IV, 07-15, Puma, 97-01, S-Max I, 06-14, Tourneo Connect, 02-13, Transit, 06-13, Transit Connect, 02-13

Engine codes: ALDA, AOBA, AOBC, AODA, AODB, AODE, AOWA, AOWB, ASDA, ASDB, CGBA, CGBB, CHBA, CHBB, CJBA, CJBB, CSDB, CSDB, DHA, DHB, DHC, DHD, DHE, DHF, DHG, EDDB, EDBB, EDBC, EDBD, EDBB, EDDC, EDDD, EDDF, EYDB, EYDC, EYDD, EYDE, EYDF, EYDG, EYDI, EYDJ, EYDL, EYPA, EYPB, EYPC, EYPD, FHA, FHD, FHE, FHF, FUJA, FUJB, FXDA, FXDB, FXDC, FXDD, FYDA, FYDB, FYDC, FYDD, FYDH, FYJA, FYJB, FYJC, GZFA, GZFB, GZFC, HMDB, HWDA, HWDB, L1L, L1N, L1Q, L1T, L1V, L1W, N4JB, NGA, NGB, NGC, NGD, Q7DA, QQDA, QQDB, QQDC, RTJA, RTJB, RTJC, RTJD, SEBA, SEWA, SHDA, SHDB, SHDC, SPJA, SPJC, SPJD, SPJE, SYDA, TBBA, TBBB, TBWA, TBWB, UADA, UTJA

Used equivalent to the following OE numbers:

- ▶ Crankshaft locking tool, Ford 303-507
- ▶ Crankshaft locking pin, Ford 303-748
- ▶ Crankshaft locking tool, Ford 303-574
- ▶ Adjusting ruler for camshafts, Ford 303-376B



Ford

Description	Article	Price EUR*
Engine timing tool set, Ford	26372L	13.60

TORQUE MULTIPLIER, FORD

for loosening and tightening the central fixing bolt of the crankshaft pulley. The torque multiplier has a gear ratio of 1:5. The tool is mandatory when working on the following Ford engines:

- ▶ 1.0 EcoBoost
- ▶ 1.0 Duratec
- ▶ 1.1 Duratec
- ▶ 2.0 Duratorq-TDCi
- ▶ 2.0 EcoBlue Diesel

Suitable for the following vehicles:

- ▶ B-Max 01/12-
- ▶ C-Max 04/10-
- ▶ Ecosport 05/12-
- ▶ Fiesta 05/12-
- ▶ Focus 01/18-
- ▶ Mondeo 10/14-
- ▶ Transit Connect 02/13-
- ▶ Transit 08/13-

Used equivalent to the following OE numbers:

- ▶ 303-1611
- ▶ 303-1611-01
- ▶ 303-1611-02



Ford

Description	Article	Price EUR*
Torque multiplier, Ford	26220L	253.90

ENGINE TIMING TOOL SET, FORD/VOLVO

For locking the camshaft and crankshaft on 1.2 VCT and 1.5 / 1.6 l EcoBoost engines.

Installed in the following vehicles:

- ▶ Ford B-Max, C-Max I/II, EcoSport II, Fiesta VI, Focus II/III, Galaxy II/III, Ka+ III, Kuga II, Mondeo IV/V, S-Max I/II, Transit Connect
- ▶ Morgan 4/4
- ▶ Volvo S60 II, V40, V60 I, V70 III

Engine codes:

- ▶ Ford: BNMA, BNMB, BNMC, HXDA, HXDB, HXJA, HXJB, HXJD, HXJE, IQDA, IQDB, IQDC, IQJA, IQJB, IQJC, IQJE, JQDA, JQDB, JQGA, JQMA, JQMB, JTBA, JTBB, JTDA, JTDB, JTJA, JTJB, JTJC, JTMA, JTWA, JTWB, KGBA, M8DA, M8DB, M8DD, M8DE, M8DF, M8MA, M8MB, M8MC, M8MD, M8ME, M9DA, M9DB, M9MA, M9MB, M9MC, M9MD, M9ME, MUDA, MUDD, PNBA, PNDA, PNDD, RHBA, RVJA, SIDA, U5JA, UEJB, UEJE, UNCA, UNCB, UNCE, UNCF, UNCI, UNCL, UNCK, UNCN, UNCP, XTDA, XTDB, YUDA
- ▶ Morgan: RHBA
- ▶ Volvo: B4164T, B4164T2, B4164T3, B4164T4

Used equivalent to the following OE numbers:

- ▶ Locking tool flywheel, Ford 303-393A
- ▶ Locking tool crankshaft, Ford 303-732
- ▶ Locking tool crankshaft, Ford 303-748
- ▶ Locking pin tensioner pulley, Ford 303-1054
- ▶ Locking tool camshaft sprockets, Ford 303-1097
- ▶ Adjusting tool crankshaft pulley, Ford 303-1550
- ▶ Locking tool camshafts, Ford 303-1552



Ford

Description	Article	Price EUR*
Engine timing tool set, Ford/Volvo	26318L	113.00

TB8000

THE EXTRA CLASS WORKSTATION



HERE IS WHERE
YOUR TOOLS BELONG



ENGINE TIMING TOOL SET, FORD

for locking the camshaft and crankshaft on 1.5 EcoBoost engines.

Installed in the following vehicles:

- ▶ Ford Fiesta VII, 17-, Focus IV, 18-, Puma, 19-, Kuga III, 19-

Engine codes: UNDA, Y1DA, Y2DA, YZDA, YZDB, YZJA

Used equivalent to the following OE numbers:

- ▶ Locking tool camshafts, Ford 303-1649
- ▶ Locking tool flywheel, Ford 303-1643
- ▶ Locking pin chain tensioner



Ford

Description	Article	Price EUR*
Engine timing tool set, Ford	26321L	181.00

ENGINE TIMING TOOL SET, FORD/VOLVO

Suitable for 2.0 I and 2.3 I engines, e.g. in the following vehicles:

- ▶ Ford: EcoSport 2 (18-, Focus 3 (11-20), Galaxy (10-), Kuga (12-), Mondeo (10-), S-Max (10-)
- ▶ Morgan Plus 4 (14-20)
- ▶ Volvo: S60 (10-15), S80 (10-16), V60 (10-14), V70 (09-14), XC60 (09-17)

Engine codes:

- ▶ Ford: MGDA, R9CB, R9CD, R9CF, R9CH, R9CI, R9DA, R9DB, R9DC, R9DD, R9MA, R9MB, R9MC, TNBA, TNCA, TNCB, TNCC, TNCD, TNCF, TNWA, TNWB, TPBA, TPWA, XQDA, YVDA
- ▶ Morgan: XQDA
- ▶ Volvo: B4204T6, B4204T7

Used equivalent to the following OE numbers:

- ▶ Fixing tool camshaft (like OE 303-1565)
- ▶ Fixing tool camshaft (like OE 303-1504 / 9.997405)
- ▶ Setting tool crankshaft sensor (like OE 303-1521 / 9.997416)
- ▶ Crankshaft locking pin (like OE 303-748 / 9.997406)
- ▶ Locking tool (like OE 303-1054)
- ▶ Holding tool crankshaft sprocket (like OE 9.997415)



Ford
Volvo

Description	Article	Price EUR*
Engine timing tool set, Ford/Volvo	26347L	95.90

ENGINE TIMING TOOL SET, FORD

for locking the camshaft and crankshaft on 1.6 16V Ti-VCT as well as 2.0 and 2.2 TDCi engines.

Installed in the following vehicles:

- ▶ Ford C-Max I, 03-10, C-Max II, 10-19, Focus II, 04-10, Focus III, 10-18, Galaxy II, 06-14, Galaxy III, 15-, Kuga I, 08-12, Kuga II, 12-19, Mondeo IV, 07-15, Mondeo V, 15-, S-Max I, 06-14, S-Max II, 15-

Engine codes: AZBC, AZWA, AZWC, G6DA, G6DB, G6DC, G6DD, G6DE, G6DF, G6DG, HXDA, IXDA, KLBA, KLWA, KNBA, KNWA, LPBA, Q4BA, Q4WA, QXBA, QXBB, QXWA, QXWB, QXWC, SIDA, T7CA, T7CC, T7CD, T7CE, T7CF, T7CI, T7CJ, T7CK, T7CL, T7CN, T7CP, T7CQ, T7DA, T7DB, T7DC, T7DD, T7MA, T7MB, T7MC, T7MD, T8CA, T8CB, T8CC, T8CD, T8CG, T8CH, T8CI, T8CJ, T8CL, T8DA, T8DE, T8MA, T8MB, T8MC, T9CA, T9CB, T9CC, T9CD, TXBA, TXBB, TXDA, TXDB, TXMA, TXWA, TYBA, TYDA, TYMA, TYWA, UFBA, UFBB, UFCA, UFCD, UFDB, UFDA, UFDB, UFMA, UFWA, UKBA, UKBB, UKDA, UKDB, UKMA, UKWA, XRMA, XRM B

Used equivalent to the following OE numbers:

- ▶ Crankshaft locking tool, Ford 303-1059
- ▶ Locking pin tensioner V-ribbed belt, Ford 303-1054
- ▶ Locking tool camshaft, Ford 303-735
- ▶ Crankshaft locking pin, Ford 303-748
- ▶ Locking tool camshafts, Ford 303-1097



Ford

Description	Article	Price EUR*
Engine timing tool set, Ford	26373L	33.90

ENGINE TIMING TOOL SET, FORD

for locking the camshaft and crankshaft on 2.0 EcoBlue engines.

Installed in the following vehicles:

- ▶ Ford Focus IV, Galaxy III, Kuga III, Mondeo V, Ranger, S-Max, Tourneo Custom, Transit Custom, Transit V363

Engine codes: BCCC, BCCD, BCDA, BCFA, BCFB, BCFE, BCFD, BCRA, BCRB, BJFA, BJFB, BJFC, BJFD, BJRA, BKFA, BKFB, BKFC, BKFD, BKRA, BKRB, BLFA, BLFB, BLFC, BLFD, BLHA, BLRA, BLRB, NOHA, POFA, POFB, T20DDOJ, YLCB, YLCC, YLDA, YLDC, YLF6, YLFA, YLFB, YLFS, YLR6, YLRA, YMCB, YMCC, YMDA, YMF6, YMFA, YMFB, YMFS, YMHA, YMR6, YMRA, YNCA, YNF6, YNFA, YNFB, YNFS, YNHA, YNR6, YNRA

Used equivalent to the following OE numbers:

- ▶ Adjustment tool crankshaft, Ford 303-1637
- ▶ Locking tool flywheel, Ford 303-1643
- ▶ Timing belt installation tool, Ford 303-1650
- ▶ Crankshaft pulley puller, Ford 303-1657



Ford

Description	Article	Price EUR*
Engine timing tool set, Ford	26319L	226.50

ENGINE TIMING TOOL SET, FORD

for locking the camshaft, crankshaft and injection pump during the following work:

- ▶ Setting the timing
- ▶ Replacing the timing chain
- ▶ Replacing the cylinder head gasket
- ▶ Replacing the injection pump

Used equivalent to the following OE numbers:

- ▶ Crankshaft lock 303 675 (21-234)
- ▶ Pump wheel lock 303-681 (21-240)

For Ford e.g. Mondeo, Transit, etc., from model year 2001 - 2004, with 2.0L and 2.4L 16V TDi / TDCi diesel engines.

Engine codes: FMBA, FMBB, D5BA, ABFA, D3FA, F3FA, D2FA, D4FA, F4FA



Ford

Description	Article	Price EUR*
Engine timing tool set, Ford	26113L	67.90

ENGINE TIMING TOOL SET, FORD

for professional engine servicing.

Suitable for 2.0 - 2.2 - 2.4 - 3.2 l Ford Duratorq diesel engines in the following vehicles:

- ▶ Ford Duratorq (Puma), Mondeo (00-07), Transit (00-11)
- ▶ Citroën: Relay (06-11), Jumper II
- ▶ Fiat: Ducato (06-11)
- ▶ Jaguar: X-Type (01-10)
- ▶ Land Rover: Defender (07-11)
- ▶ LDV: Convoy (02-06)
- ▶ Peugeot: Boxer III (06-11)

Engine codes:

- ▶ 2.0l: ABFA, D3FA, D5BA, D6BA, F3FA, F1FA, FMBA, HJBA, HJBB, HJBC, HJBE, N7BA, N7BB
- ▶ 2.2l: QJBA(BG), QJBB, QJBC, QJBD
- ▶ 2.2l: 4HM, 4HU, 4HV, P8FA, P22DTE, QVFA, QWFA
- ▶ 2.4l: 244DT, D0FA, D2FA, D2FB, D4FA, F4FA, FXFA, H9FA, H9FB, HEFA, HFFA, JXFA, PHFA, ZSD 424
- ▶ 3.2l: SAFA

Used equivalent to the following OEM numbers:

- ▶ Pump removal tool 303-249
- ▶ Camshaft locking tool 303-675
- ▶ Camshaft radial gasket 303-679A
- ▶ Adjustment tool for engine covers OE 303-682
- ▶ Flywheel locking bolt 303-698
- ▶ Retaining tool for high-pressure pumps 303-1151
- ▶ Injection pump arrester tool 303-1317



Citroën
Fiat
Ford
Jaguar
Land Rover
Peugeot

Description	Article	Price EUR*
Engine timing tool set, Ford	26173L	101.90

CRANKSHAFT LOCKING PIN, FORD

for locking the crankshaft when changing the timing chain or when setting the timing.

Suitable for Ford Transit 2.2 TDCi 74 / 92 / 99 / 114 KW engines from 2006.

Engine codes: CVRA, CVRB, CYRA, CYRB, DRRRA, DRRRB, USRA, USRB

Used equivalent to OE number 303-1562.



Ford

Description	Article	Price EUR*
Crankshaft locking pin, Ford	26205L	11.30

ENGINE TIMING TOOL SET, CITROËN / PEUGEOT

Very comprehensive universal set for vehicles with PSA petrol and diesel engines. Includes tools for locking the flywheel, crankshaft and camshaft and for adjusting the timing belt tension.

Installed in the following vehicles:

- ▶ Citroën AX, Berlingo, BX, C15, C2, C3, C4, C5, C8, DS4, DS5, Evasion, Jumpy, Nemo, Saxo, Xantia, Xsara, ZX
- ▶ Fiat Scudo, Ulysse, Ducato
- ▶ Lancia Phedra, Zeta
- ▶ Peugeot 106, 205, 206, 207, 306, 307, 308, 309, 406, 407, 508, 607, 806, 807, 1007, 3008, 5008, Bipper, Expert, Partner, Boxer
- ▶ Suzuki Grand Vitara

Suitable for petrol engines:

- ▶ 1.1, 1.4, 1.4 16V, 1.6, 1.6 16V, 1.8 16V, 2.0, 2.0 16V

Diesel engines:

- ▶ 1.9, 2.0, 2.2 D/TD/TDI/HDI/JTD



Citroën
Fiat
Lancia
Peugeot
Suzuki

Description	Article	Price EUR*
Engine timing tool set, Citroën / Peugeot	26381L	164.50

CRANKSHAFT PULLEY LOCKING TOOL, DACIA / NISSAN / RENAULT / SMART

For locking the pulley to loosen the central fastening screw.

Suitable for the following vehicles

- ▶ Dacia Dokker, Duster, Jogger, Lodgy, Logan, Sandero
- ▶ Nissan Juke (F15), Micra (K14), Pulsar (C13), Qashqai (J11)
- ▶ Renault Captur, Clio, Kadjar, Kangoo II, Kaptur, Megane III/IV, Scenic, Twingo III
- ▶ Smart Fortwo and Forfour

For engine codes:

- ▶ Nissan: HR09DET, HRA2DDT
- ▶ Renault: H4B, H4M, H4D, H5F
- ▶ Smart: 281.910, 281.920

Used equivalent to the following OE numbers:

- ▶ Renault MOT-2006, MOT-2025, MOT-2054
- ▶ Smart 281.589.00.40.00



Citroën
Fiat
Lancia
Peugeot
Suzuki

Description	Article	Price EUR*
Crankshaft pulley locking tool, Dacia / Nissan / Renault / Smart	26349L	33.90

ENGINE TIMING TOOL SET, FIAT / OPEL

for locking the camshaft and crankshaft on 1.2 and 1.4 petrol engines

Installed in the following vehicles:

- ▶ Alfa Romeo Giulietta ,10-20, Mito ,08-18
- ▶ Fiat Brava I, Bravo I, Bravo II, Doblo 263, Idea, Linea, Marea, Palio, Panda ,06-, Punto 176, Punto 188, Grande Punto 199, Stilo 192, Tipo 356, 500 312, 500 351
- ▶ Lancia Delta ,08-14, Musa ,04-12, Y ,95-03, Ypsilon ,03-11
- ▶ Opel Combo Tour ,11-18

Engine codes:

- ▶ Fiat: 169A3, 176B9, 182B2, 188A5, 192B2, 198A1, 198A4, 199A6, 199A8, 312B3, 312B4, 312B6, 55277, 843A1, 940A6, 940B1, 940B7, 940B8, 955A1
- ▶ Opel: A14FC, A14FP

Used equivalent to the following OE numbers:

- ▶ Locking tool camshaft sprocket, Opel EN-50781
- ▶ Locking tool crankshaft, Opel EN-50780, Fiat 2.000.004.500, Ford 303-1480
- ▶ Locking tool camshafts, Opel EN-46781
- ▶ Adjusting tool tensioner, Opel EN-50782, Fiat 1.860.987.000, Ford 303-1560
- ▶ Alignment tool TDC position, Fiat 1.860.992.000
- ▶ Locking tool flywheel, Fiat 1.871.000.400



Alfa Romeo
Fiat
Lancia
Opel
Vauxhall

Description	Article	Price EUR*
Engine timing tool set, Fiat / Opel	26323L	101.90

ENGINE TIMING TOOL SET, FIAT/FORD/IVECO/PSA

for adjusting the timing on 2.2l and 3.0l diesel engines, installed in the following vehicles:

- ▶ Citroën Jumper II 2.2 and 3.0 HDI engines
- ▶ Fiat Ducato (250) 2.2l and 3.0l Multijet
- ▶ Ford Transit, Tourneo 2.2 TDCi
- ▶ Iveco Daily 3/4/5/6 3.0 Diesel
- ▶ Peugeot Boxer 2.2 and 3.0 HDI engines

Engine codes:

- ▶ Citroen: 4HG, 4HH, 4HJ, 4HU, 4HV
- ▶ Fiat: F1CE0441A, F1CE0481D, F1CE3481E, F1CE3481M, F1CE3481N, F1CFA401A, F1CFA401C
- ▶ Ford: CV24, CVF5, CVFF, CVR5, CY14, CY24, CYF4, CYF5, CYFA, CYFB, CYFC, CYFD, CYFF, CYFG, CYR5, DRF4, DRF5, DRFA, DRFB, DRFC, DRFD, DRFE, DRFF, DRFG, DRR5, P8FA, P8FB, PGFA, PGFB, QVFA, QWFA, SRFA, SRFB, SRFC, SRFD, SRFE, UHFA, UHFB, UHFC, USF6, USR6, UYR6
- ▶ Iveco: F1CE0441A, F1CE0481A, F1CE0481B, F1CE0481E, F1CE0481F, F1CE0481H, F1CE0481L, F1CE0481P, F1CE0489EIII, F1CE3481B, F1CE3481C, F1CE3481D, F1CE3481J, F1CE3481K, F1CE3481L, F1CFA401A, F1CFA401B, F1CFA401C
- ▶ Peugeot: F30DT, F30DTE, P22DTE



Citroën
Fiat
Peugeot
Iveco

Description	Article	Price EUR*
Engine timing tool set, Fiat/Ford/Iveco/PSA	26343L	169.90

LOCKING TOOL FLYWHEEL

for locking the flywheel during repair work on the timing drive

Used equivalent to the following OE number:

- ▶ Fiat 1.860.161.000
- ▶ Mercedes 607 589 01 40 00
- ▶ PSA 0153-A

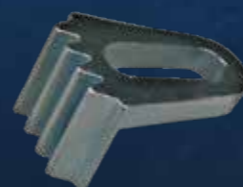

Citroën
Fiat
Mercedes-Benz
Peugeot

Description	Article	Price EUR*
Locking tool flywheel	26377L	5.10

ENGINE TIMING TOOL SET, FIAT / MERCEDES / NISSAN / OPEL / RENAULT

for professional engine repair for 1.6, 1.8 und 2.0 litre diesel engines.

Suitable for the following vehicles:

- ▶ Fiat Talento (296) 2016-
- ▶ Mercedes C-Klasse (205) 2014-2018, Vito/Metris (447) 2014-
- ▶ Nissan Qashqai (J10/J11) 2011-, X-Trail (T31/T32) 2007-, NV300 (X82) 2016-, Primastar (X83) 2006-
- ▶ Opel Vivaro (X82/X83) 2006-
- ▶ Renault Espace (JK0/JR) 2006-, Kadjar (HA/HL) 2015-, Koleos (HY/HC) 2008-, Laguna (BG0/KG0/BTO/KTO/DT0) 2006-, Latitude (L70) 2011-, Megane (BM0/BZ0/B9A) 2005-, Scénic and Grand Scénic (JM0/JZ0/J9) 2005-, Talisman (LP/KP) 2015-, Vel Satis (BJ0) 2005-, Trafic (JL/JG) 2006-

Engine Codes:

- ▶ M1D, M9R, R9M, OM622 and OM626



Fiat
Mercedes-Benz
Nissan
Opel
Renault
Vauxhall

Description	Article	Price EUR*
Engine timing tool set, Fiat / Mercedes / Nissan / Opel / Renault	26336L	79.50

ENGINE TIMING TOOL SET, NISSAN / OPEL / RENAULT

Very comprehensive universal set for vehicles with Renault petrol and diesel engines. Includes tools for locking the flywheel, crankshaft and camshaft and for adjusting the timing belt tension.

Installed in the following vehicles:

- ▶ Dacia Dokker, Duster, Logan, Lodgy, Sandero
- ▶ Jeep CJ5, Cherokee
- ▶ Lada Largus
- ▶ Mitsubishi Carisma, Space Star
- ▶ Nissan Kubistar, Primastar
- ▶ Opel Arena, Movano, Vivaro
- ▶ Renault Avantime, Clio, Espace, Fluence, Kangoo, Laguna, Megane, Modus, Rapid, Safrane, Scenic, Thalia, Twingo, R5, R9, R11, R19, R21, R25, Trafic, Master
- ▶ Suzuki Samurai

Engine codes: D7F, E5F, E7F, E7J, F1N, F3N, F3P, F3R, F4P, F4R, F7P, F7R, F8M, F8Q, F9Q, G8T, J5R, J7R, J8S, K4J, K4M, K7J, K7M, N7Q, N7U, NF8, S8U, S9U, S9W



Jeep
Lada
Mitsubishi
Nissan
Opel
Renault
Suzuki
Vauxhall

Description	Article	Price EUR*
Engine timing tool set, Nissan / Opel / Renault	26387L	124.50

ENGINE TIMING TOOL SET, MERCEDES / NISSAN / OPEL / RENAULT

for locking the camshaft and crankshaft on 1.5, 1.9, 2.2 and 2.5 Renault Diesel engines

Installed in the following vehicles:

- ▶ Dacia Dokker, Duster, Logan, Lodgy, Sandero
- ▶ Mercedes A-Klasse W176, A-Klasse W177, B-Klasse W246, B-Klasse W247, CLA C117, CLA C118, GLA X156, Citan W415, Citan W420
- ▶ Nissan Almera, Cube, Juke, Kubistar, Micra, Note, Primera, Qashgai, Tiida, Interstar, Evalia, NV200, Primastar, NV250
- ▶ Opel Movano, Vivaro
- ▶ Renault Avantime, Captur, Clio, Espace, Fluence, Kadjar, Kangoo, Laguna, Megane, Modus, Scenic, Thalia, Twingo, Vel Satis, Trafic, Master
- ▶ Suzuki Grand Vitara, Jimny

Engine codes:

- ▶ Mercedes OM607, OM608
- ▶ Renault F9Q, G9M, G9T, G9U, K9K

Used equivalent to the following OE numbers:

- ▶ Crankshaft locking tool, ø 7 mm, Renault MOT-1536
- ▶ Locking tool intake Camshaft, Renault MOT-1534
- ▶ Locking tool exhaust camshaft, Renault MOT-1537
- ▶ Pump wheel locking tool, Renault MOT-1538
- ▶ Crankshaft locking tool, Renault MOT-1489
- ▶ Crankshaft locking tool, ø 8 mm, Renault MOT-1430
- ▶ Tensioning tool timing belt, Renault MOT-1543
- ▶ Locking pin high pressure pump, ø 3 mm
- ▶ Locking tool flywheel, Mercedes 607 589 01 40 00



Mercedes-Benz
Nissan
Opel
Renault
Suzuki
Vauxhall

Description	Article	Price EUR*
Engine timing tool set, Mercedes / Nissan / Opel / Renault	26376L	79.50

ENGINE TIMING TOOL SET, ALFA / FIAT / FORD / LANCIA

contains the most important tools for repair work on Alfa Romeo, Fiat, Ford and Lancia engines with 1.2 and 1.4 l. 8-valve petrol engines.

Suitable for the following vehicles:

- ▶ Alfa Romeo Mito ,11-18
- ▶ Fiat New 500 ,07-, Doblo/Cargo ,05-10, Fiorino ,08-, Qubo ,09-, Grande Punto ,07-12, Idea ,04-12, Linea ,07-11, Panda ,09-12 und Grande Punto ,05-09, Punto Evo ,09-11, Punto ,12-18
- ▶ Ford Ka ,09-16
- ▶ Lancia Ypsilon ,06-17, Musa ,05-12

Engine codes:

- ▶ Alfa, Fiat, Lancia 169A4.000, 199A7.000, 350A1.000, 955A9.000
- ▶ Ford 169A4.000 (FP4)

Used equivalent to the following OE numbers:

- ▶ Locking tool crankshaft, Fiat 2.000.004.500, Ford 303-1480
- ▶ Adjusting tool camshafts, Fiat 2.000.004.400, Ford 303-1479
- ▶ Locking tool camshaft sprocket, Fiat 2.000.004.200, Ford 303-1477
- ▶ Locking tool camshaft, Fiat 2.000.004.300, Ford 303-1478
- ▶ Adjusting tool tensioner, Fiat 1.860.987.000



Alfa Romeo
Fiat
Ford
Lancia

Description	Article	Price EUR*
Engine timing tool set, Alfa / Fiat / Ford / Lancia	26358L	79.50

ENGINE TIMING TOOL SET, ALFA ROMEO / FIAT

for locking and aligning the intake and exhaust camshafts e.g. when changing the timing belt.

- ▶ Incl. Special insert with 12.5 mm (1/2") drive for disassembling the phase adjuster
- ▶ 23 Precise locking tools for the intake and exhaust camshafts prevent the camshafts from rotating after installation and position them in the timing belt mounting position
- ▶ Locking tools are numbered and additionally marked in color to prevent any confusion
- ▶ With the TDC mandrel and a micrometer clock (not included), an accurate alignment of the crankshaft is possible

Suitable for following vehicles:

- ▶ Fiat Bravo 1.4 12V & 2.0 20V; Brava 1.4 12V & 2.0 20V Marea 2.0 20V; Coupe 1.8 16V; Barchetta 1.8 16V; Punto 1.8 16V
- ▶ Lancia K5 2.0 20V; 4 cyl. VIS engines from BJ, .96 Delta 1.8 16V Step A; Dedra 1.8 16V Step A; Y10 1.4 12V
- ▶ Alfa 145 + 146 1400 & 1600 16V Step A; 147 1600 16V Step A; 147 105 hp, 147 1600 eco 103PS; 155 1400 & 1600 16V Step A, 156 1600 16V Step A; 156 1800 - 2000 16V 156 2000 JTS; 166 2000; GTV 2000 JTS - Spider GT 2000 JTS 16V 165hp



Alfa Romeo
Fiat
Lancia

Description	Article	Price EUR*
Engine timing tool set, Alfa Romeo / Fiat	26016L	260.50

ENGINE TIMING TOOL SET, ALFA ROMEO / FIAT / LANCIA

for operations on the timing chain with 1.4 l MultiAir engines.

Suitable for the following vehicles:

- ▶ Alfa Romeo: Giulietta (2010-), MiTo (2008-2018)
- ▶ Fiat: Bravo II (2006-2014), Grande Punto (2005-2009), Punto Evo (2008-2012), Punto (2012-2018)
- ▶ Lancia: Delta III (2008-2014)

Engine codes: 198A7.000, 940A2.000, 955A2.000, 955A6.000, 955A7.000, 955A8.000, 955B1.000

Used equivalent to the following OE numbers:

- ▶ 2.000.034.400
- ▶ 2.000.004.500
- ▶ 1.860.987.000



Alfa Romeo
Fiat
Lancia

Description	Article	Price EUR*
Engine timing tool set, Alfa Romeo / Fiat / Lancia	26194L	56.50

ENGINE TIMING TOOL SET, FIAT / IVECO

contains the most important tools for repair work on 2.3 and 2.8 l. Fiat and Iveco engines.

Suitable for the following vehicles:

- ▶ Fiat Ducato ,01-'06, Ducato ,06-
- ▶ Iveco Daily III ,99-'06, Daily IV ,06-'11, Daily V ,11-'14, Daily VI ,14-'19

Engine codes: 8140.43B, 8140.43C, 8140.43K, 8140.43R, F1AE0481A, F1AE0481B, F1AE0481C, F1AE0481D, F1AE0481F, F1AE0481G, F1AE0481H, F1AE0481M, F1AE0481N, F1AE0481R, F1AE0481U, F1AE0481V, F1AE3481A, F1AE3481B, F1AE3481C, F1AE3481D, F1AE3481E, F1AE3481G, F1AGL4111, F1AGL4112, F1AGL4113, F1AGL4114, F1AGL411A, F1AGL411B, F1AGL411C, F1AGL411D, F1AGL411G, F1AGL411H, F1AGL411J, F1AGL411M

Used equivalent to the following OE numbers:

- ▶ Locking tool camshafts, Fiat 99.360.614
- ▶ Locking pin crankshaft, Fiat 99.360.615
- ▶ Locking pin camshaft, Fiat 1.860.617.000
- ▶ Locking pin crankshaft, Fiat 2.000.018.200



Fiat
Iveco

Description	Article	Price EUR*
Engine timing tool set, Fiat / Iveco	26359L	33.90

FLYWHEEL LOCKING TOOL, HYUNDAI / KIA

The locking tool is fitted in place of the starter and locks the flywheel via the starter's ring gear. An indispensable tool when:

- ▶ Loosening the crankshaft bolt
- ▶ Changing the timing chain / timing belt

Suitable for:

- ▶ Hyundai Accent IV/V, Creta, Elantra IV/V/VI, Genesis, i10 I/II/III, i20 I/II/III, i30, i40, ix20, ix35, Kona, Santa Fé II/III/IV, Solaris, Sonata V/VI/VII, Tucson, Veloster
- ▶ Kia Carens III/IV, Cee'd, Cerato I/II/III/IV, Magentis II, Optima, Picanto II/III, Rio III/IV, Seltos, Sorento II/III, Soul I/II/III, Sportage III/IV, Stonic, Venga

Engine codes: D4FB, D4FC, D4FD, D4HA, D4HB, D4UU, G3LA, G3LC, G4FA, G4FC, G4FD, G4FG, G4FJ, G4KD, G4KE (nur Optima), G4KF, G4KH, G4KJ, G4LA, G4LC, G4LD, G4LK, G4NA, G4NC, G4ND, G4NE

Used equivalent to the following OE numbers::

- ▶ Kia 09231-2B100
- ▶ Kia 09231-3N100



Hyundai
Kia

Description	Article	Price EUR*
Flywheel locking tool, Hyundai / Kia	26325L	38.00

ENGINE TIMING TOOL SET, HYUNDAI / KIA

includes the essential tools for installation and removal of camshaft and high-pressure pump sprockets, as well as for checking and setting the camshaft timing on current Hyundai and Kia models.

Suitable for the following vehicles:

- ▶ Kia Carens III (UN), Carens IV, Cee'd I (ED), Cee'd II (JD), Cerato I (LD), Optima (TF), Picanto I (BA), Rio III (UB), Rio IV (YB), Soul I (AM), Soul II (PS), Sportage III (SL), Sportage IV (QL), Venga (YN)
- ▶ Hyundai Accent (MC), Accent (RB), Elantra (HD), Getz (TB), i10 (PA), i20 (PB), i20 (GB), ix20 (JC), i30 (GD9), ix35 (LM), i40 (VF), Matrix (FC), Tucson (TLE)

Motor codes:

- ▶ D3FA, D3FF, D4FA, D4FB, D4FB-H, D4FB-L, D4FC, D4FD, D4FD-H, D4FD-L

Used equivalent to the following OE numbers: 09331-2A000 / 09231-2A100

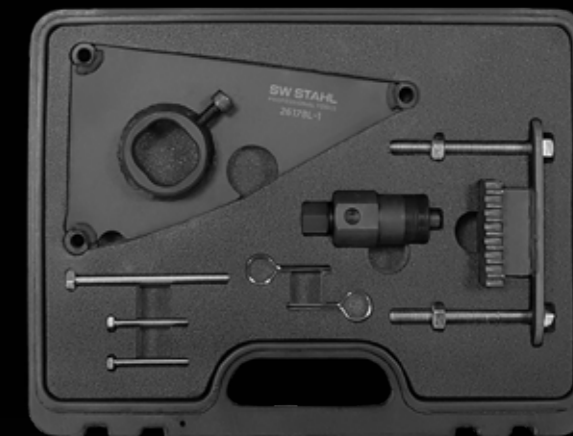

Hyundai
Kia

Description	Article	Price EUR*
Engine timing tool set, Hyundai / Kia	26178L	90.50

PULLER SET CAMSHAFT SPROCKETS

for removing 5- or 6-spoke camshaft sprockets. The different hook shapes allow almost unlimited use.

For Audi, Seat, Škoda and VW with 4-, 5-, 6- and 8-cylinder engines.

Engine codes: AAH, ABC, ACK, ACZ, AEJ, AFB, AGA, AGB, AGE, AGP, AGR, AHA, AHF, AJG, AJK, AKB, AKC, AKE, AKF, AKN, ALF, ALG, ALH, ALW, AML, AMM, AMX, ANK, APB, APC, APR, APS, APZ, AQD, AQF, AQG, AQH, AQJ, AQM, ARE, ARJ, ARN, ARS, ART, ARU, ASG, ASJ, ASM, ASV, ASY, ATQ, ATX, AUW, AUX, AVB, AVF, AVN, AVP, AWA, AWN, AWX, AXQ, AXW, AXX, AYM, AYQ, AYS, AZA, AZB, AZR, AZV, BAU, BBD, BBG, BCS, BCY, BCZ, BDG, BDH, BDV, BEL, BES, BFC, BFL, BFM, BGB, BGH, BGJ, BGK, BGW, BHD, BHW, BHX, BHZ, BJJ, BJK, BJL, BKD, BKE, BKP, BLB, BLR, BLX, BLY, BMA, BMB, BMN, BMP, BMR, BNA, BPG, BPJ, BPW, BPY, BRB, BRC, BRD, BRE, BRF, BRV, BUL, BUZ, BVA, BVE, BVF, BVG, BVX, BVY, BVZ, BWA, BWE, BWJ, BWT, BWV, BYD, BYK, BZC, CCGA, CDLA, CDLB, CDLC, CDLD, CDLF, CDLG, CDLH, CDLJ, CDLK, CDMA, CEBA, CEBB, CECA, CECB, CRZA

Used equivalent to the following OE numbers:

- ▶ VAG T40001



Audi
Seat
Škoda
VW

Description	Article	Price EUR*
Puller set camshaft sprockets	26351L	73.50

CAMSHAFT FIXING TOOL

Is required for changing timing belts and all jobs related to engine timing

- ▶ Can be used for all DOHC diesel and petrol engines
- ▶ Fixing by camshafts being mutually supported
- ▶ Fixing pins made of hardened steel, leading to long service life
- ▶ Suitable for universal use thanks to two central arms of different lengths
- ▶ Special locking handle for the central arm bolts can be turned to a space-saving position



Description	Article	Price EUR*
Camshaft fixing tool	26018L	67.90

ENGINE TIMING TOOL SET, VAG TSI/TFSI EA-211 ENGINES

 Audi
 Seat
 Škoda
 VW

With this engine timing tool set, the user can adjust and check the timing of EA 211 (1.0/1.2/1.4/1.5l) TSI/TFSI petrol engines from the Volkswagen Group without having to rely on computer-assisted tools. The kit includes a battery-powered digital inclinometer, which, in combination with precision-manufactured adapters and alignment tools, enables accurate timing adjustment. Connection to the vehicle's OBD system is not necessary as long as the adjustment processes are carried out correctly in accordance with the operating instructions.

Suitable for the following vehicles:

- ▶ Audi (from 2012), Cupra (from 2020), Seat (from 2012), Skoda (from 2012) and Volkswagen (from 2012)

Engine codes: CHPA, CHPB, CHZA, CHZB, CHZC, CHZD, CHZE, CHZF, CHZG, CHZJ, CHZK, CHZL, CJA, CJZB, CJZC, CJZD, CMBA, CPTA, CPVA, CPVB, CPWA, CUKB, CUKC, CXSA, CXSB, CYVA, CYVB, CYVD, CZCA, CZCB, CZCC, CZDA, CZDB, CZDD, CZDE, CZEA, DACA, DACB, DADA, DBYA, DFYA, DGEA, DGEB, DJKA, DJKD, DJVA, DKJA, DKLA, DKLB, DKLC, DKLD, DKRA, DKRB, DKRC, DKRD, DKRE, DKRF, DLAA, DLAB, DLAC, DPBA, DPBC, DPBE, DPCA, DSHA, DTBA, DTBB, DUCA, DUCB, DUMA, DXDB, DXDE, DXTA, DXUA, DZWA

THE TIMING TOOL FOR VAG 1.0 - 1.5 TSI/EA-211 ENGINES



Extension kit 26421L:
For 1.0 TSI and 1.6 MPI engines



Description	Article	Price EUR*
Engine timing tool set, VAG 1.5 TSI petrol	26420L	294.50
Extension kit for 1.0 TSI and 1.6 MPI engines	26421L	69.90
Inclinometer digital	26412L	54.50

ART.: ET2601-EN